



CNC TOOLING

Quality tooling at sensible prices



HIGH PERFORMANCE TOOLING

Available from our stock range

CNC2016



ABOUT US

Welcome to Wealden's CNC catalogue, which represents our current range of CNC tooling and offers competitive pricing and many innovative solutions. All these cutters and tools are manufactured for and often designed by Wealden.

With over 30 years' of cutter, saw and profiling technology we are worth talking to if you have questions about these tools. Many of our most supportive customers came to us for advice and stay with us for price and service. Our quality is second to none.

Those new to CNC are sometimes daunted by the cost of tooling - and from some suppliers they are right to be. However, durability and long accurate run times are as important as economy when running a seriously expensive machine. To this end Wealden offer replaceable tipped tools in many forms. More expensive than disposable cutters initially, our replaceable tips are highly competitive and hugely cut costs, even in the short term.

For heavy duty CNC cutting and profiling we have solid carbide replaceable tips on phenomenally rigid tungsten alloy shanks. We know how to improve your productivity.

To meet the challenges of highly abrasive materials such as MDF, plywood, composites and other hard to machine materials, our range includes solid carbide, PCD and numerous spiral, compression and other more exotic solutions to our customers' problems.

Look at the range. Ask us questions. Try us out.

You'll be glad you did.



CONTACT US:

Telephone: **01580 890500**

Fax: **01580 890222**

Email: sales@wealdentool.com

Website: www.wealdentool.com

Wealden Tool Company Limited
2, Clinton Business Centre
Lodge Road
Staplehurst
Kent TN12 0QF



CONTENTS

Spirals		Multi Profile Moulding Set	23
Up Cut - STC	1	Multi Profile Set	24
Down Cut - STC	2	Multi Profile System	25
Compression - STC	3	Bull Nose	26
Ball End Up Cut - STC	4	Ovolo Bead	27
Rougher Up Cut - STC	5	V Groove	28
Finishing Chipbreaker Up Cut - STC	6	Finger Joint	29
Finishing Chipbreaker Down Cut - STC	7	Engraving V Bits	30
Finishing 3 flute Up Cut - STC	8	Adjustable Groover	31
Finishing 3 flute Down Cut - STC	9	Ball Nose Profile	32
		Arris Rounding	33
Acrylic cutters		PCD	
Straight Flute - STC	10	Bookcase Strip	34
Helical Flute Up Cut - STC	11	Down-shear	35
Helical Flute Down Cut - STC	12	Economy Spiral Compression	36
		Spiral Compression - re-serviceable	37
Easy-fix	13	Drills	
Versofix		Dowel Drills	38
Straight 1/2" shank	14	Cylinder Boring Bits	39
Straight 1/4" shank	15		
Straight Lefthand Rotation	16	Accessories	
Straight Two Flute	17	ER Collets	40
Straight Two+Two Flutes	18	OZ collets	41
Lock Pocket Mortice	19	Tool Holder Assembly Device	41
Up Down Shear	20	Tool Holders & Nuts	42
Surfacing Rebating	21	Pull Studs & Wrenches	43
Surface Trepanning	22		

COPYRIGHT © 2016 Wealden Tool Company. No part of this publication may be transmitted or reproduced by any means without our express permission. All rights reserved.

Wealden Tool Company is a trading name of Wealden Tool Company Limited. Registered in England number 4697332

wealdentool.com

Sales: 01580 890500 Fax: 01580 890222 Email: sales@wealdentool.com





STC ROUTER CUTTERS

Upcut Spirals - STC

Up Cut Spirals are designed to pull chips up and away from the part being cut and, in addition, will prevent burning when plunge cutting. They deliver a very satisfactory cut with fast chip exit and removal. Up Cut spirals should be chosen if dust or chips present problems. All cutters in this range have two cutting flutes.

Part Number	ØD mm	ØD inch	C1	Ød	OL	Price (Ex VAT)
T1U3000L	3.00	0.118	12.0mm	3.0mm	64.0mm	£14.78
T4U3000	3.00	0.118	12.0mm	1/4"	50.8mm	£15.86
T4U3175	3.18	1/8	12.7mm	1/4"	50.8mm	£16.70
T4U3967	3.97	5/32	12.7mm	1/4"	50.8mm	£15.86
T4U4000	4.00	5/32	14.0mm	1/4"	50.8mm	£15.86
T4U4762	4.76	3/16	19.0mm	1/4"	50.8mm	£16.61
T4U5000	5.00	0.197	19.0mm	1/4"	50.8mm	£16.61
T8U5000	5.00	0.197	19.0mm	8mm	76.2mm	£24.65
T4U6000	6.00	15/64	19.0mm	1/4"	50.8mm	£17.17
T8U6000A	6.00	15/64	19.0mm	8mm	76.2mm	£23.46
T8U6000B	6.00	15/64	25.0mm	8mm	76.2mm	£26.83
T4U6350	6.35	1/4	25.4mm	1/4"	63.5mm	£18.75
T2U7937	7.94	5/16	25.4mm	1/2"	76.2mm	£45.17
T8U8000B	8.00	5/16	25.0mm	8mm	76.2mm	£26.30
T8U8000C	8.00	5/16	32.0mm	8mm	76.2mm	£28.36
T2U9525	9.53	3/8	31.7mm	1/2"	76.2mm	£47.15
T2U1000B	10.00	25/64	32.0mm	1/2"	76.2mm	£44.42
T2U1000L	10.00	25/64	40.0mm	1/2"	88.9mm	£49.25
T2U1200C	12.00	15/32	38.0mm	1/2"	88.9mm	£47.40
T2U1200L	12.00	15/32	54.0mm	1/2"	101.6mm	£54.75
T2U1270A	12.70	1/2	31.7mm	1/2"	76.2mm	£53.46
T2U1270C	12.70	1/2	38.1mm	1/2"	88.9mm	£60.96
T2U1270E	12.70	1/2	50.8mm	1/2"	101.6mm	£53.83
T7U214140B	14.00	9/16	42.0mm	14mm	90.0mm	£61.50
T7U216160B	16.00	5/8	52.0mm	16mm	100.0mm	£69.90

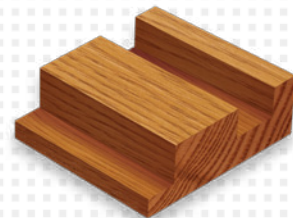
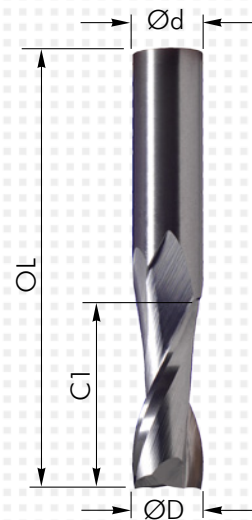

Ød = shank diameter
 ØD = cutting diameter
 OL = overall length
 C1 = blade length



wealdentool.com

Sales: 01580 890500 Fax: 01580 890222 Email: sales@wealdentool.com



STC ROUTER CUTTERS

Downcut Spirals - STC

A range of high quality micro-grain solid carbide spiral downcut cutters for use in CNC machines. These specialist cutters offer high performance routing, with fine finish and high feed rates.

All cutters are two flute except item marked # which is single flute.

Part Number	ØD mm	ØD inch	C1	Ød	OL	Price (Ex VAT)
T1D3000L	3.00	0.118	12.0mm	3.0mm	64.0mm	£14.79
T4D3000	3.00	0.118	12.0mm	1/4"	50.8mm	£15.86
T4D3175	3.18	1/8	12.7mm	1/4"	50.8mm	£15.86
T4D3967	3.97	5/32	12.7mm	1/4"	50.8mm	£15.86
T4D4000	4.00	5/32	14.0mm	1/4"	50.8mm	£15.86
T4D4762	4.76	3/16	19.0mm	1/4"	50.8mm	£16.61
T4D5000	5.00	0.197	19.0mm	1/4"	50.8mm	£16.61
T8D5000	5.00	0.197	19.0mm	8mm	76.2mm	£22.17
T4D6000	6.00	15/64	19.0mm	1/4"	50.8mm	£17.17
T6D6000	6.00	15/64	25.0mm	6mm	60.0mm	£17.08
T8D6000A	6.00	15/64	19.0mm	8mm	76.2mm	£23.46
T8D6000B	6.00	15/64	25.0mm	8mm	76.2mm	£26.83
T4D6350	6.35	1/4	25.4mm	1/4"	63.5mm	£18.75
T8D8000B	8.00	5/16	25.0mm	8mm	76.2mm	£24.50
T8D8000S#	8.00	5/16	25.0mm	8mm	76.2mm	£25.00
T8D8000C	8.00	5/16	32.0mm	8mm	76.2mm	£28.36
T9D8500	8.50	0.335	20.0mm	10mm	76.2mm	£33.50
T3D9525	9.53	3/8	31.7mm	3/8"	76.2mm	£43.11
T2D9525	9.53	3/8	31.7mm	1/2"	76.2mm	£43.21
T2D1000B	10.00	25/64	32.0mm	1/2"	76.2mm	£47.15
T2D1200C	12.00	15/32	38.0mm	1/2"	88.9mm	£52.10
T2D1270A	12.70	1/2	31.7mm	1/2"	76.2mm	£42.67
T2D1270C	12.70	1/2	38.1mm	1/2"	88.9mm	£46.11
T2D1270E	12.70	1/2	50.8mm	1/2"	101.6mm	£61.08
T7D214140B	14.00	9/16	42.0mm	14mm	90.0mm	£61.50
T7D216160B	16.00	5/8	52.0mm	16mm	100.0mm	£69.90

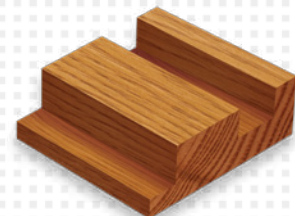
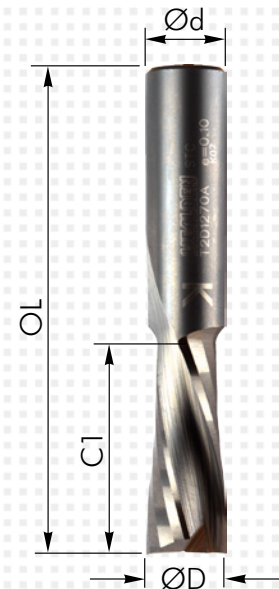

Ød = shank diameter
 ØD = cutting diameter
 OL = overall length
 C1 = blade length





STC ROUTER CUTTERS

Compression Spirals - STC

These two flute compression spirals have up and down shear cut on the same cutter. This provides down shear cutting on the top and up shear cutting on the bottom of boards.

Ideal for edge trimming on double faced veneered boards, these cutters ensure a good finish on both faces of laminated and solid timber boards.

Part Number	ØD mm	ØD inch	C1	Ød	OL	C2	Price (Ex VAT)
T1C3000	3.00	0.118	20mm	3mm	64.0mm	3.8mm	£18.75
T1C4000	4.00	5/32	20mm	4mm	64.0mm	5mm	£18.75
T4C6350	6.35	1/4	25mm	1/4"	64.0mm	6mm	£29.58
T8C8000	8.00	5/16	25mm	8mm	70.0mm	7mm	£37.00
T3C9525	9.53	3/8	32mm	3/8"	76.2mm	12mm	£41.83
T3C9525M	9.53	3/8	32mm	3/8"	76.2mm	5mm	£41.83
T9C1000	10.00	25/64	35mm	10mm	80.0mm	9mm	£50.20
T2C1270	12.70	1/2	42mm	1/2"	102.0mm	13mm	£60.29
T2C1270M	12.70	1/2	25mm	1/2"	66.9mm	9mm	£53.61

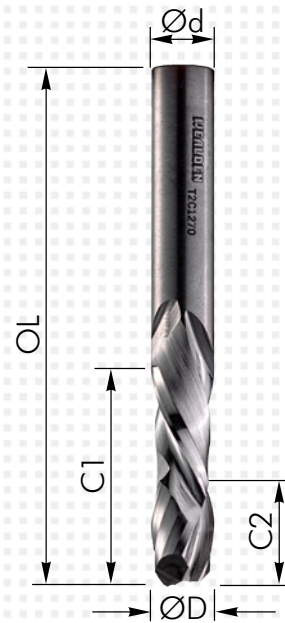

Ød = shank diameter
 ØD = cutting diameter
 OL = overall length
 C1 = blade length
 C2 = up cut area



wealdentool.com

Sales: 01580 890500 Fax: 01580 890222 Email: sales@wealdentool.com



STC ROUTER CUTTERS

Ball End Upcut Spirals - STC

A range of high quality micro-grain solid carbide spiral upcut cutters with ball ends to give clean transition between depths. These cutters are primarily aimed at 3-D carving in CNC machines.

All cutters are two flute.

Part Number	ØD mm	ØD inch	C1	Ød	OL	Price (Ex VAT)
T1UB3000	3.00	0.118	25mm	3mm	70mm	£19.06
T4UB6350	6.35	1/4	25.4mm	1/4"	63.5mm	£21.38
T8UB8000	8.00	5/16	25mm	8mm	76.2mm	£28.79
T2UB1270A	12.70	1/2	31.7mm	1/2"	76.2mm	£54.58
T2UB1270L	12.70	1/2	54.0mm	1/2"	101.6mm	£69.11

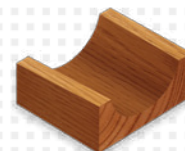
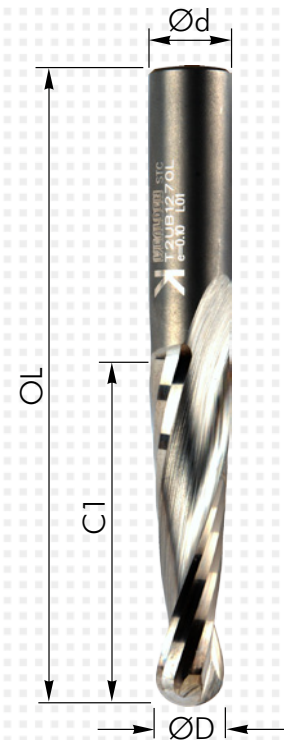

Ød = shank diameter
 ØD = cutting diameter
 OL = overall length
 C1 = blade length





STC ROUTER CUTTERS

Roughing Spiral Three Flute - STC

Roughing cutters are designed for high feed rates on CNC routers in dense materials such as hardwoods and plywood, when surface finish is not important. The rougher bit makes the first cut, followed by a second cut using a profile type tool.

This cutter will produce a rippled edge to the cut. It is extremely quiet and smooth in operation, even with heavy cuts and high feed rates.

Part Number	ØD mm	ØD inch	C1	Ød	OL	Price (Ex VAT)
T8UR8000A	8.00	5/16	25mm	8mm	76.2mm	£28.75
T8UR8000B	8.00	5/16	32mm	8mm	76.2mm	£29.75
T9UR1000A	10.00	25/64	25mm	10mm	76.2mm	£39.00
T9UR1000B	10.00	25/64	32mm	10mm	76.2mm	£39.50
T2UR1270A	12.70	1/2	25mm	1/2"	76.2mm	£54.75
T2UR1270B	12.70	1/2	32mm	1/2"	76.2mm	£55.00
T2UR1270E	12.70	1/2	52mm	1/2"	101.6mm	£73.50

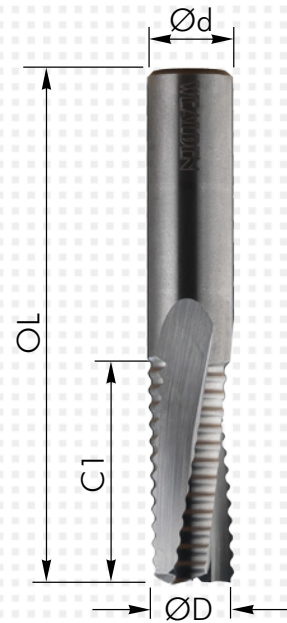

Ød = shank diameter
 ØD = cutting diameter
 OL = overall length
 C1 = blade length



wealdentool.com

Sales: 01580 890500 Fax: 01580 890222 Email: sales@wealdentool.com



STC ROUTER CUTTERS

Finishing Chipbreaker Spiral Three Flute Upcut STC

A range of three flute upcut spiral cutters, which give high feed rates with low noise. The spiral chipbreaker design gives a fine serrated finish with good chip clearance and low chip loading. In many situations the finish may be acceptable without any further machining operations.

* This cutter is two flute only, due to the small diameter.

The cutters are supplied with a locator circlip, which may be removed if not required.

Part Number	ØD mm	ØD inch	C1	Ød	OL	Price (Ex VAT)
T5UC208060*	6.00	0.2362	22mm	8mm	70mm	£29.50
T5UC308080L	8.00	0.3149	32mm	8mm	80mm	£39.36
T5UC310100	10.00	0.3937	32mm	10mm	80mm	£41.30
T5UC312120	12.00	0.4724	32mm	1/2"	80mm	£64.43
T5UC312120X	12.00	0.4724	52mm	1/2"	100mm	£77.86
T5UC314140X	14.00	0.5512	52mm	14mm	100mm	£84.32
T5UC316160X	16.00	0.6299	72mm	16mm	120mm	£106.42
T5UC318180L	18.00	0.7086	72mm	18mm	120mm	£128.52
T5UC320200	20.00	0.7874	52mm	20mm	100mm	£114.75
T5UC320200X	20.00	0.7874	102mm	20mm	150mm	£150.00



Ød = shank diameter
 ØD = cutting diameter
 OL = overall length
 C1 = blade length



wealdentool.com

Sales: 01580 890500 Fax: 01580 890222 Email: sales@wealdentool.com



STC ROUTER CUTTERS

Finishing Chipbreaker Spiral Three Flute Downcut STC

A range of three flute upcut spiral cutters, which give high feed rates with low noise. The spiral chipbreaker design gives a fine serrated finish with good chip clearance and low chip loading. In many situations the finish may be acceptable without any further machining operations.

The cutters are supplied with a locator circlip, which may be removed if not required.

Part Number	ØD mm	ØD inch	C1	Ød	OL	Price (Ex VAT)
T5DC308080L	8.00	0.3149	32mm	8mm	80mm	£39.36
T5DC310100	10.00	0.3937	32mm	10mm	80mm	£41.30
T5DC312120	12.00	0.4724	32mm	1/2"	80mm	£64.43
T5DC312120X	12.00	0.4724	52mm	1/2"	100mm	£77.86
T5DC314140X	14.00	0.5512	52mm	14mm	100mm	£84.32
T5DC316160X	16.00	0.6299	72mm	16mm	120mm	£106.42
T5DC318180L	18.00	0.7086	72mm	18mm	120mm	£128.52
T5DC320200	20.00	0.7874	52mm	20mm	100mm	£114.75
T5DC320200X	20.00	0.7874	102mm	20mm	150mm	£150.00



Ød = shank diameter
 ØD = cutting diameter
 OL = overall length
 C1 = blade length



wealdentool.com

Sales: 01580 890500 Fax: 01580 890222 Email: sales@wealdentool.com



STC ROUTER CUTTERS

Finishing Spiral Three Flute Upcut STC

A range of three flute upcut spiral cutters, which give high feed rates with fine surface finish. Upcut spirals require good hold-down as they can pull the work up from the bed, they also provide good chip removal from the work.

The cutters are supplied with a locator circlip, which may be removed if not required.

Part Number	ØD mm	ØD inch	C1	Ød	OL	Price (Ex VAT)
T7U310100B	10.00	0.3937	42mm	10mm	90mm	£40.00
T7U312120B	12.00	0.4724	42mm	12mm	90mm	£47.00
T7U312120C	12.00	0.4724	52mm	12mm	100mm	£52.50
T7U316160B	16.00	0.6299	52mm	16mm	100mm	£68.50
T7U320200A	20.00	0.7874	52mm	20mm	100mm	£94.00
T7U320200B	20.00	0.7874	72mm	20mm	120mm	£125.00

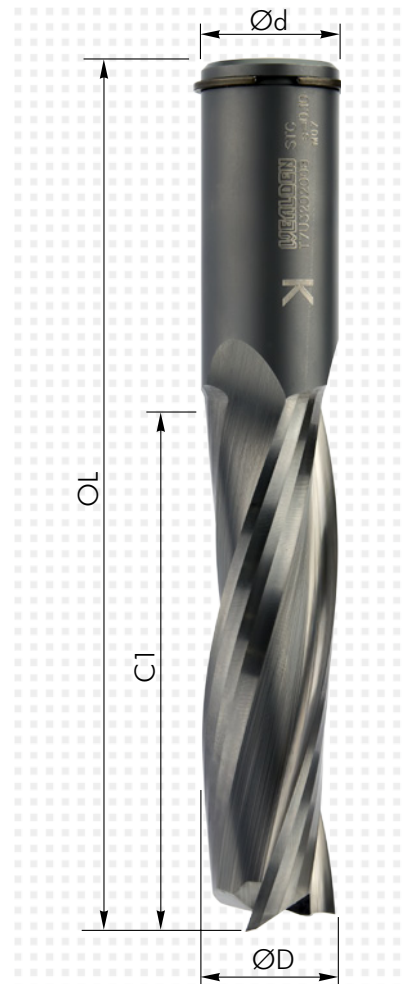

Ød = shank diameter
 ØD = cutting diameter
 OL = overall length
 C1 = blade length





STC ROUTER CUTTERS

Finishing Spiral Three Flute Downcut STC

A range of three flute upcut spiral cutters, which give high feed rates with fine surface finish. Downcut spirals give better hold-down when working on vacuum beds but require efficient extraction as the cutting action pushes the cut material downwards.

The cutters are supplied with a locator circlip, which may be removed if not required.

Part Number	ØD mm	ØD inch	C1	Ød	OL	Price (Ex VAT)
T7D310100B	10.00	0.3937	42mm	10mm	90mm	£40.00
T7D312120B	12.00	0.4724	42mm	12mm	90mm	£47.00
T7D312120C	12.00	0.4724	52mm	12mm	100mm	£52.50
T7D316160B	16.00	0.6299	52mm	16mm	100mm	£68.50
T7D320200A	20.00	0.7874	52mm	20mm	100mm	£94.00
T7D320200B	20.00	0.7874	72mm	20mm	120mm	£125.00

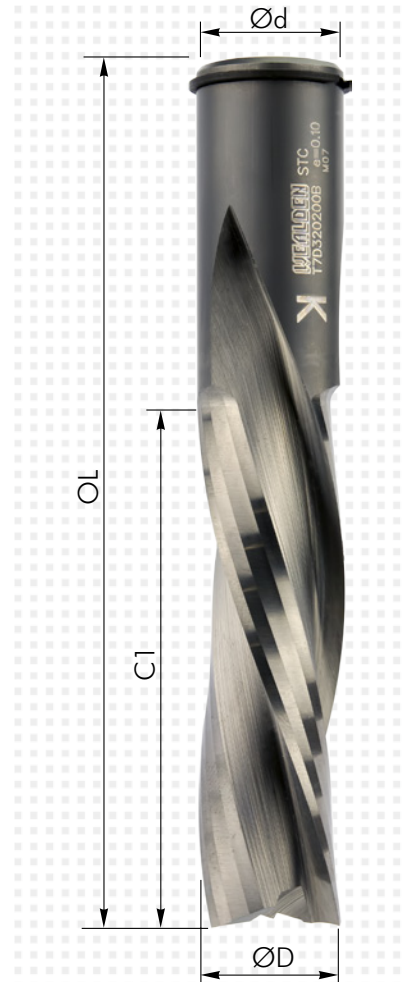

Ød = shank diameter
 ØD = cutting diameter
 OL = overall length
 C1 = blade length





STC ROUTER CUTTERS

Acrylic Spirals Straight Flute - STC

A range of helical fluted up-cut solid tungsten carbide cutters specially ground for cutting acrylic. The polished flute design allows for smooth feed rate, efficient chip clearance and a cleaner finish.

Single flute solid carbide cutters offer fast cutting and are especially suited to cutting low melting point plastics. The design of two flute cutters gives reduced contact with the material, plus gradual lead-in when first cutting and is the perfect preparation before flame polishing of Perspex.

Part Number	ØD mm	ØD inch	C1	Ød	OL	Flutes	Price (Ex VAT)
T4AS635CZ1	6.35	1/4	25mm	1/4	65mm	1	£17.54
T4AS635AZ2	6.35	1/4	15mm	1/4	65mm	2	£18.11
T4AS635CZ2	6.35	1/4	25mm	1/4	65mm	2	£18.42
T8AS800CZ1	8.00	5/16	32mm	8mm	80mm	1	£23.25
T8AS800CZ2	8.00	5/16	32mm	8mm	80mm	2	£25.71

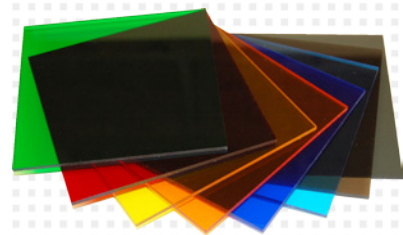
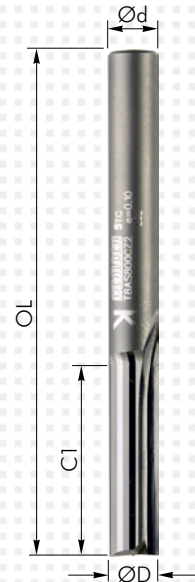

Ød = shank diameter
 ØD = cutting diameter
 OL = overall length
 C1 = blade length





STC ROUTER CUTTERS

Acrylic Helical Flute Up Cut - STC

A range of helical fluted up-cut solid tungsten carbide cutters specially ground for cutting acrylic. The polished flute design allows for smooth feed rate, efficient chip clearance and a cleaner finish.

Single flute solid carbide cutters offer fast cutting and are especially suited to cutting low melting point plastics. The design of two flute cutters gives reduced contact with the material, plus gradual lead-in when first cutting and is the perfect preparation before flame polishing of Perspex.

Part Number	ØD mm	ØD inch	C1	Ød	OL	Flutes	Price (Ex VAT)
T4AU300AZ2	3.00	0.118	12mm	1/4	65mm	2	£24.25
T4AU400AZ2	4.00	5/32	14mm	1/4	65mm	2	£24.92
T4AU600BZ2	6.00	15/64	19mm	1/4	65mm	2	£23.80
T4AU630AZ1	6.35	1/4	10mm	1/4	65mm	1	£22.00
T4AU630BZ1	6.35	1/4	20mm	1/4	65mm	1	£22.92
T8AU400AZ2	4.00	5/32	14mm	8mm	80mm	2	£31.25
T8AU600BZ2	6.00	15/64	19mm	8mm	80mm	2	£31.65
T8AU800BZ2	8.00	5/16	25mm	8mm	80mm	2	£33.21
T8AU800CZ1	8.00	5/16	30mm	8mm	80mm	1	£28.20

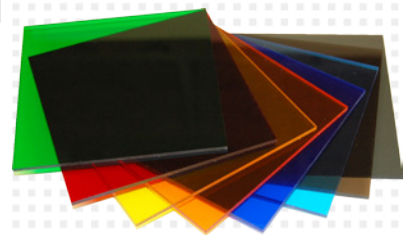
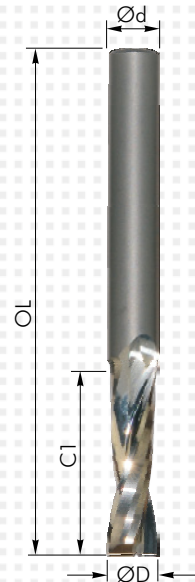

Ød = shank diameter
 ØD = cutting diameter
 OL = overall length
 C1 = blade length



wealdentool.com

Sales: 01580 890500 Fax: 01580 890222 Email: sales@wealdentool.com



STC ROUTER CUTTERS

Acrylic Helical Flute Down Cut - STC

A range of helical fluted down-cut solid tungsten carbide cutters specially ground for cutting acrylic. The polished flute design allows for smooth feed rate, efficient chip clearance and a cleaner finish.

Single flute solid carbide cutters offer fast cutting and are especially suited to cutting low melting point plastics. The design of two flute cutters gives reduced contact with the material, plus gradual lead-in when first cutting and is the perfect preparation before flame polishing of Perspex.

Part Number	ØD mm	ØD inch	C1	Ød	OL	Flutes	Price (Ex VAT)
T4AD400AZ2	4.00	5/32	14mm	1/4	65mm	2	£24.92
T4AD600BZ2	6.00	15/64	19mm	1/4	65mm	2	£23.80
T8AD400AZ2	4.00	5/32	14mm	8mm	80mm	1	£31.25
T8AD600BZ2	6.00	15/64	19mm	8mm	80mm	2	£31.65
T8AD800CZ2	8.00	5/16	25mm	8mm	80mm	1	£33.21
T8AD800DZ1	8.00	5/16	30mm	8mm	80mm	2	£28.20

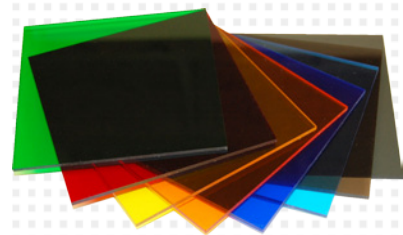
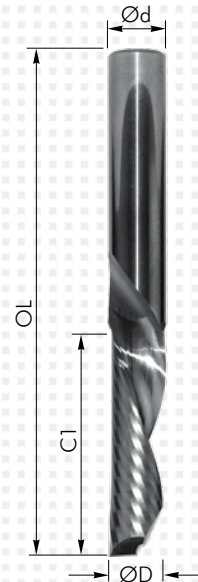

Ød = shank diameter
 ØD = cutting diameter
 OL = overall length
 C1 = blade length



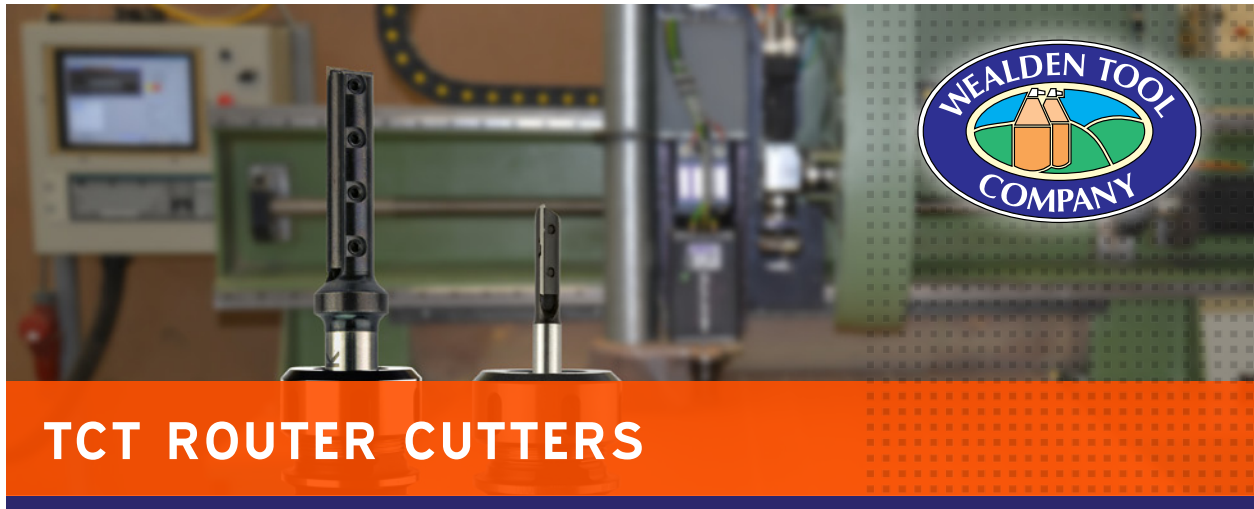

TCT ROUTER CUTTERS

Easy-fix[®] Replaceable Tip

A range of replaceable tip single flute cutters. These economical production cutters have low cost solid tungsten carbide replaceable knives with positive location for easy replacement and long life. Supplied complete with blade and key.

Part Number	ØD	Ød	C1	OL	Blade part no.	Price (Ex VAT)
TE10808020	8.0mm	8mm	20mm	60mm	TK4120	£33.00
TE11308020	8.0mm	1/2"	20mm	67mm	TK4120	£33.00
TE10801030	10.0mm	8mm	30mm	70mm	TK5530	£34.58
TE11312730	12.7mm	1/2"	30mm	80mm	TK5530	£36.00
TE11312050	12.0mm	1/2"	50mm	103mm	TK5550	£41.00
TE11312750	12.7mm	1/2"	50mm	103mm	TK5550	£41.00
TE11314050	14.0mm	1/2"	49mm	103mm	TK5649	£43.50
TE11318030	18.0mm	1/2"	29mm	103mm	TK5629	£46.50

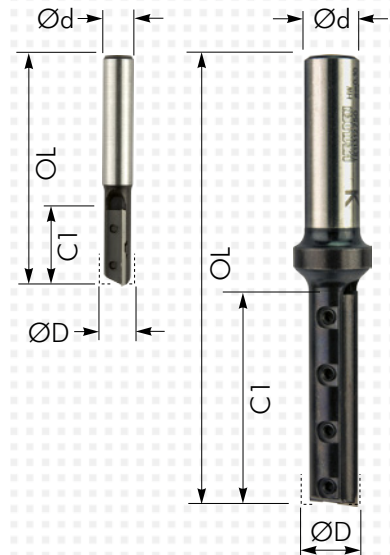

Spare blades	Description	Size	Price (Ex VAT)
TK4120	Blade	20 x 4.1 x 1.1mm	£1.61
TK4120B	Box of 10 blades	20 x 4.1 x 1.1mm	£13.00
TK5530	Blade	30 x 5.5 x 1.1mm	£1.72
TK5530B	Box of 10 blades	30 x 5.5 x 1.1mm	£13.75
TK5550	Blade	20 x 5.5 x 1.1mm	£2.20
TK5550B	Box of 10 blades	20 x 5.5 x 1.1mm	£19.50
TK5629	Blade	30 x 6.5 x 1.1mm	£3.60
TK5629B	Box of 10 blades	30 x 6.5 x 1.1mm	£32.50
TK5649	Blade	50 x 6.5 x 1.1mm	£3.95
TK5649B	Box of 10 blades	50 x 6.5 x 1.1mm	£35.50

Spare parts	Description	Price (Ex VAT)
F002079	Torx key T8	£2.58
F002085	Torx key T9	£2.58
KT15	Torx key T15	£2.04
TQ254	Clamp screw M2.5 x 4.5 - head 3.5 c/sk	£1.29
TQ256	Clamp screw M2.5 x 6 - head 3.5 c/sk	£1.29
TQ404	Grub screw M4 x 4	£1.11
TQ408	Clamp screw M4 x 6 - head 6mm	£1.79
TQ406	Clamp screw M4 x 6 - head 8.5mm	£1.36

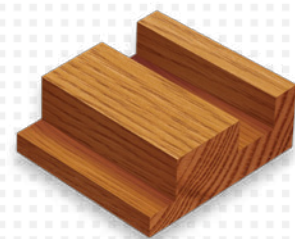

Ød = shank diameter
 ØD = cutting diameter
 OL = overall length
 C1 = blade length



wealdentool.com

Sales: 01580 890500 Fax: 01580 890222 Email: sales@wealdentool.com



TCT ROUTER CUTTERS

Replaceable Tip Versofix - 1/2" shank

A range of replaceable tip single flute cutters. The TC inserts have a ground-in chip breaker to provide optimum cutting angle and ensure good chip formation even in the smallest diameters. A special coating is applied to the TC inserts, which increases surface hardness and wear resistance. Each cutter is supplied with a blade.

Part Number	ØD	Ød	C1	OL	Blade part no.	Price (Ex VAT)
K69400	8.0mm	1/2"	20mm	68mm	K69883	£55.13
K69421	9.5mm	1/2"	20mm	68mm	K69883	£50.40
K69401	10.0mm	1/2"	20mm	68mm	K69883	£55.13
K69402	12.0mm	1/2"	20mm	68mm	K69883	£37.63
K69408	12.7mm	1/2"	30mm	74mm	K69884	£63.88
K69420	12.7mm	1/2"	50mm	94mm	K69886	£57.05
K69403	14.0mm	1/2"	30mm	74mm	K69881	£58.80
K69409	14.0mm	1/2"	50mm	94mm	K69882	£58.28
K69404	15.0mm	1/2"	30mm	74mm	K69881	£47.43
K69405	16.0mm	1/2"	30mm	74mm	K69881	£50.75
K69410	16.0mm	1/2"	50mm	94mm	K69882	£81.55
K69406	18.0mm	1/2"	30mm	74mm	K69881	£65.63
K69411	18.0mm	1/2"	50mm	94mm	K69882	£63.18
K69407	20.0mm	1/2"	30mm	74mm	K69881	£54.25
K69412	20.0mm	1/2"	50mm	94mm	K69882	£64.75

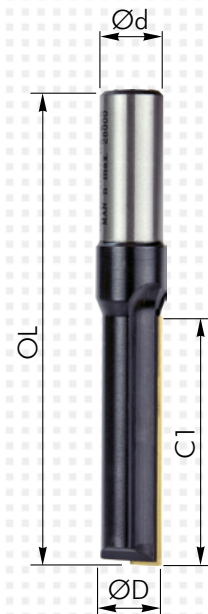

Spare Parts	Description	Size	Price (Ex VAT)
K69881	Blade	30 x 10 x 1.5mm	£8.40
K59881B	Box of 10 blades	30 x 10 x 1.5mm	£84.00
K69882	Blade	50 x 10 x 1.5mm	£11.73
K69882B	Box of 10 blades	50 x 10 x 1.5mm	£117.30
K69883	Blade	20 x 5.5 x 1.1mm	£10.50
K69883B	Box of 10 blades	20 x 5.5 x 1.1mm	£105.00
K69884	Blade	30 x 6.5 x 1.1mm	£10.15
K69884B	Box of 10 blades	30 x 6.5 x 1.1mm	£101.50
K69886	Blade	50 x 6.5 x 1.1mm	£12.25
K69886B	Box of 10 blades	50 x 6.5 x 1.1mm	£122.50

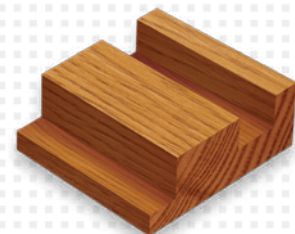

Ød = shank diameter
 ØD = cutting diameter
 OL = overall length
 C1 = blade length

wealdentool.com

Sales: 01580 890500 Fax: 01580 890222 Email: sales@wealdentool.com





TCT ROUTER CUTTERS

Replaceable Tip Versofix - 1/4" shank

A range of replaceable tip single flute cutters. The TC inserts have a ground-in chip breaker to provide the optimum cutting angle, ensuring good chip formation even in the smallest diameters. A special coating is applied to the TC inserts which increases the surface hardness and wear resistance. Each cutter is supplied with a blade.

Part Number	ØD	Ød	C1	OL	Blade part no.	Price (Ex VAT)
K69150	8.0mm	1/4"	20mm	63mm	K69883	£44.10
K69151	10.0mm	1/4"	20mm	63mm	K69883	£40.08
K69152	12.0mm	1/4"	20mm	63mm	K69883	£43.93
K69153	14.0mm	1/4"	20mm	59mm	K69880	£43.93
K69154	15.0mm	1/4"	20mm	59mm	K69880	£42.42
K69155	16.0mm	1/4"	20mm	59mm	K69880	£46.20
K69156	18.0mm	1/4"	20mm	59mm	K69880	£48.65
K69157	20.0mm	1/4"	20mm	59mm	K69880	£49.18
K69158	22.0mm	1/4"	20mm	59mm	K69880	£59.50

Spare Parts	Description	Size	Price (Ex VAT)
K69880	Blade	20 x 10 x 1.5mm	£11.38
K69880B	Box of 10 blades	20 x 10 x 1.5mm	£113.80
K69883	Blade	20 x 5.5 x 1.1mm	£10.50
K69883B	Box of 10 blades	20 x 5.5 x 1.1mm	£105.00

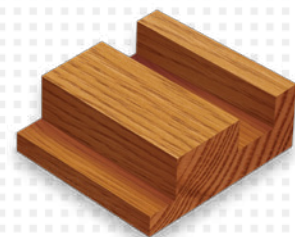
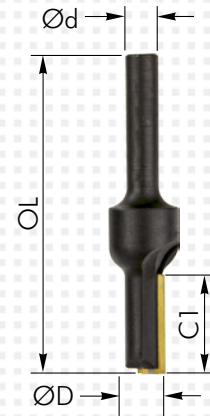

Ød = shank diameter
 ØD = cutting diameter
 OL = overall length
 C1 = blade length



wealdentool.com

Sales: 01580 890500 Fax: 01580 890222 Email: sales@wealdentool.com



TCT ROUTER CUTTERS

Replaceable Tip Versofix Left Hand Rotation

Two cutters from the VERSOFIX range which are suitable for use in machines with left hand rotation. Each cutter is supplied complete with blades.

The TC inserts have a ground-in chip breaker to provide optimum cutting angle and ensure good chip formation even in the smallest diameters. A special coating is applied to the TC inserts, which increases surface hardness and wear resistance.

Part Number	ØD	Ød	C1	OL	Blade part no.	Price (Ex VAT)
K69416	12.7mm	1/2"	30mm	74mm	K69884	£67.62
K69417	14.0mm	1/2"	50mm	74mm	K69882	£65.94

Spare Parts	Description	Size	Price (Ex VAT)
K69882	Blade	50 x 10 x 1.5mm	£11.73
K69882B	Box of 10 blades	50 x 10 x 1.5mm	£117.30
K69884	Blade	30 x 6.5 x 1.1mm	£10.15
K69884B	Box of 10 blades	30 x 6.5 x 1.1mm	£101.50

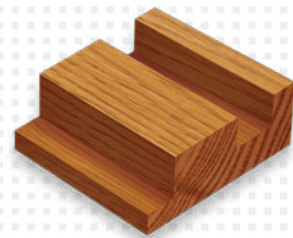
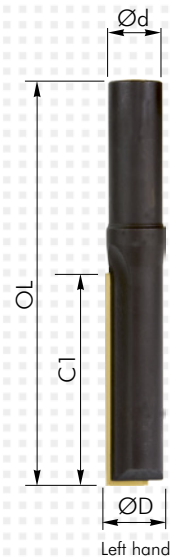

Ød = shank diameter
 ØD = cutting diameter
 OL = overall length
 C1 = blade length





CNC ROUTER CUTTERS

Straight Two Flute Replaceable Tip



Disposable insert swop-tip[®] cutter suitable for grooving, rebating and sizing in coated or uncoated man-made boards.

Replaceable tip cutters offer the benefit of a constant diameter and easy maintenance without removal from the machine.

Part Number	ØD	C1	OL	Ød	C2	Price (Ex VAT)
NA1842030	20mm	29mm	90mm	20mm	50mm	£77.50
NA1842050	20mm	49mm	110mm	20mm	50mm	£83.75

Spare Parts	Description	Size	Price (Ex VAT)
NA0050308	Knife	29x9x1.5mm	£3.35
NA0050508	Knife	49x9x1.5mm	£3.95
TQ354	Screw	M3.5 x 4	£1.36
NA0050015	Torx key	T15	£2.04

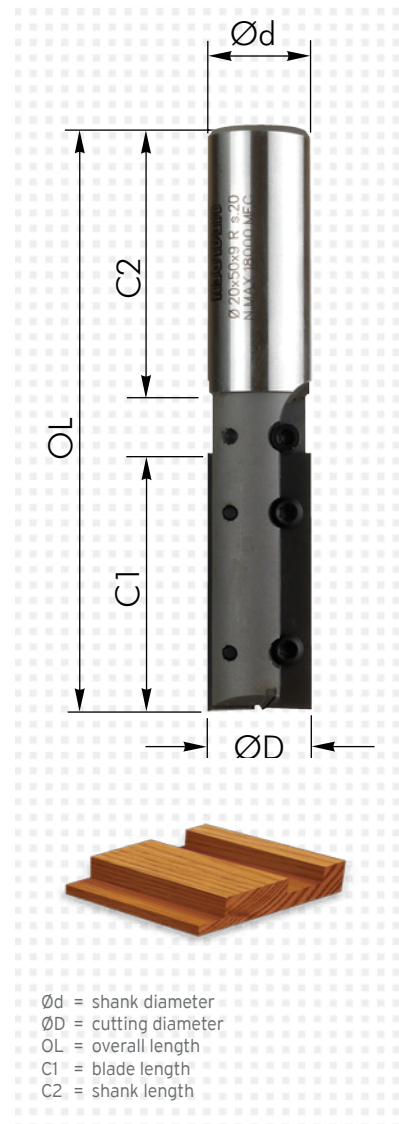



CNC ROUTER CUTTERS

Straight Two + Two Flutes



Disposable insert compression cutter with alternate knives, which can be independently replaced. Suitable for trimming on double-sided veneered and laminated board.

Replaceable tip cutters offer the benefit of a constant diameter and easy maintenance without removal from the machine.

Part Number	ØD	C1	OL	Ød	C2	Price (Ex VAT)
NA1852052	20mm	52mm	125mm	20mm	50mm	£118.75

Spare Parts	Description	Size	Price (Ex VAT)
NA0050030	Knife	29.5x12x1.5mm	£1.72
TQ406	Screw	M4 x 6	£1.36
NA0050015	Torx key	T15	£2.04

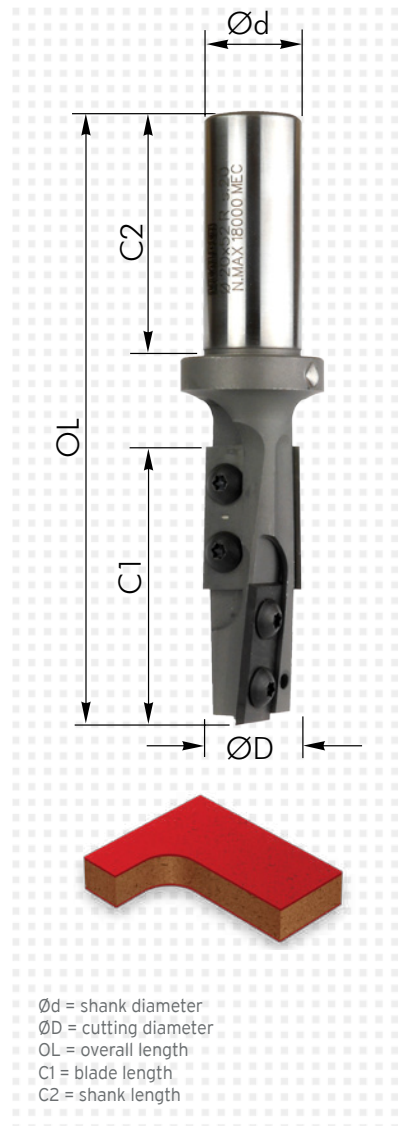



Lock Pocket Mortise Cutter



Deep pocket cutter designed to rout lock mortise cut-outs and deep mortises. The tool body is made of high alloy steel for extreme rigidity and is fitted with two solid carbide swop-tip® knives with chip breaker.

Replaceable tip cutters offer the benefit of a constant diameter and easy maintenance without removal from the machine.

Part Number	ØD	C1	OL	Ød	C2	Price (Ex VAT)
NA1651616	16mm	23mm	150mm	16mm	100mm	£220.00

Spare Parts	Description	Size	Price (Ex VAT)
NA0050162	Knife	23x7x1.5mm 2RT	£7.17
NA0050163	Knife	23x7x1.5mm 3RT	£7.17
TQ304	Screw	M3 x 4	£1.36
F002085	Torx key	T9	£3.66

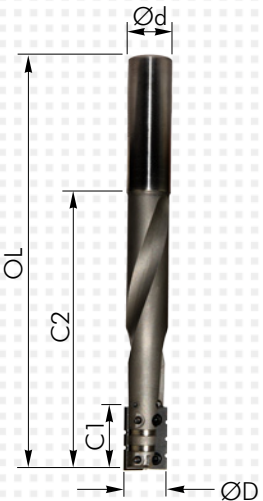

Ød = shank diameter
 ØD = cutting diameter
 OL = overall length
 C1 = blade length
 C2 = max cutting depth





Up Down Shear Cutter



Replaceable tip straight router cutter complete with two up and down shear flutes for an extra fine finish and centre tip for improved boring.

Replaceable inserts ensure a constant cutting diameter and finish quality.

Part Number	ØD	C1	OL	Ød	Price (Ex VAT)
NA8073200	20mm	30mm	110mm	20mm	£108.05
NA8073220	20mm	50mm	130mm	20mm	£122.06

Spare Parts	Description	Size	Price (Ex VAT)
NA8073203	TC Knife (box 10)	16 x 7 x 1.5mm	£48.53
NA8073204	TC Knife (box 10)	28 x 7 x 1.5mm	£53.95
TQ305	Torx Screw	M3 x 4	£1.38
F002085	Torx Key	T9	£3.66

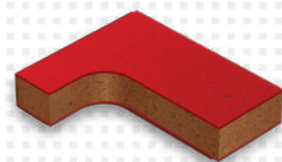

Ød = shank diameter
 ØD = cutting diameter
 OL = overall length
 C1 = max cutting depth





CNC ROUTER CUTTERS

Surfacing Rebating Cutter



A large three flute replaceable TC swop-tip[®] cutter for spoil board machining, surfacing and rebating where the rebate angle is 90 degrees.

Replaceable tip cutters offer the benefit of a constant diameter and easy maintenance without removal of the tooling from the machine.

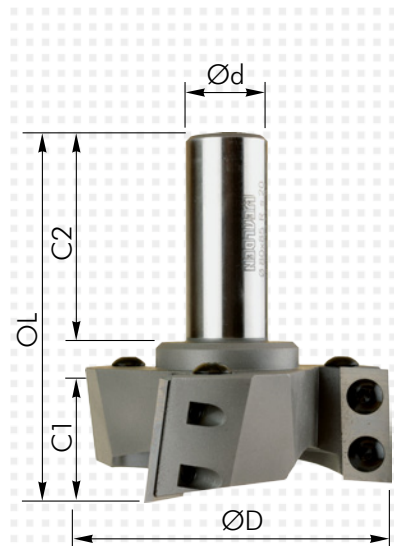

Part Number	ØD	C1	OL	Ød	C2	Price (Ex VAT)
NA1642080	80mm	30mm	85mm	20mm	50mm	£190.00

Spare Parts	Description	Size	Price (Ex VAT)
NA0005312	Knife	30mm	£3.60
TQ406	Screw	M4 x 6	£1.36
KT15	Torx key	T15	£2.04



Ød = shank diameter
 ØD = cutting diameter
 OL = overall length
 C1 = blade length
 C2 = shank length



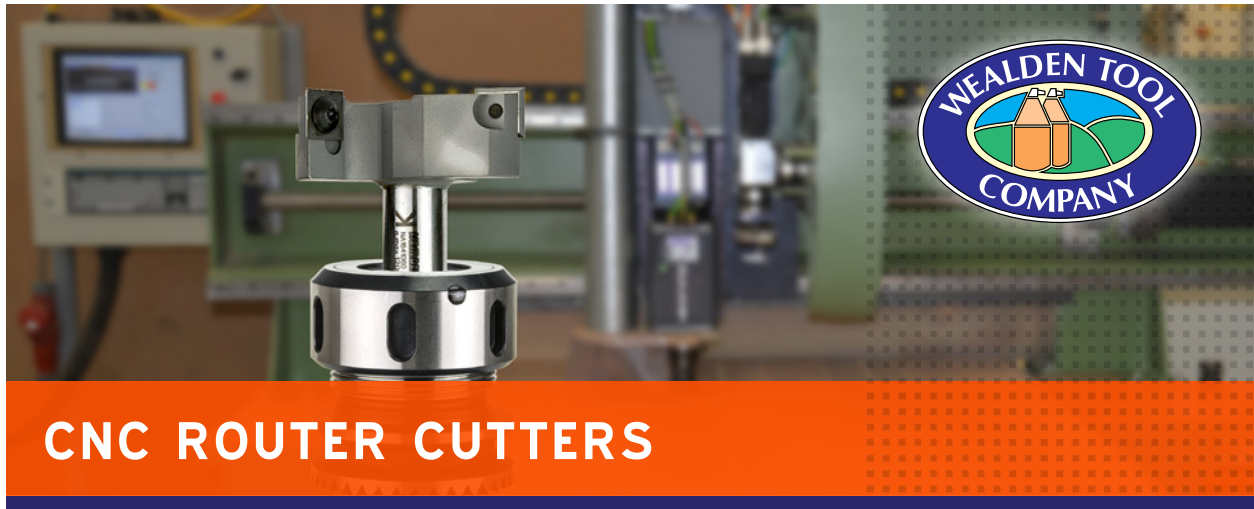

Surface Trepanning Three Wing Cutter

Skimming tool for CNC beds with standard TC 12mm swop-tip® knives. The half inch shank version meets the requirements for hand feeding and may be used in portable routing machines.

Replaceable inserts ensure a constant cutting diameter and finish quality.

Part Number	ØD	C1	OL	Ød	Shank length	Price (Ex VAT)
NA1641050	50mm	12mm	70mm	12.7mm	49mm	£82.50
NA1641060	60mm	12mm	70mm	16mm	49mm	£92.50

Spare Parts	Description	Size	Price (Ex VAT)
TK12	TC Knife	12x12x1.5mm	£1.47
TQ405	Screw	M4 x 5	£0.65
KT15	Hex Key	T15	£2.04

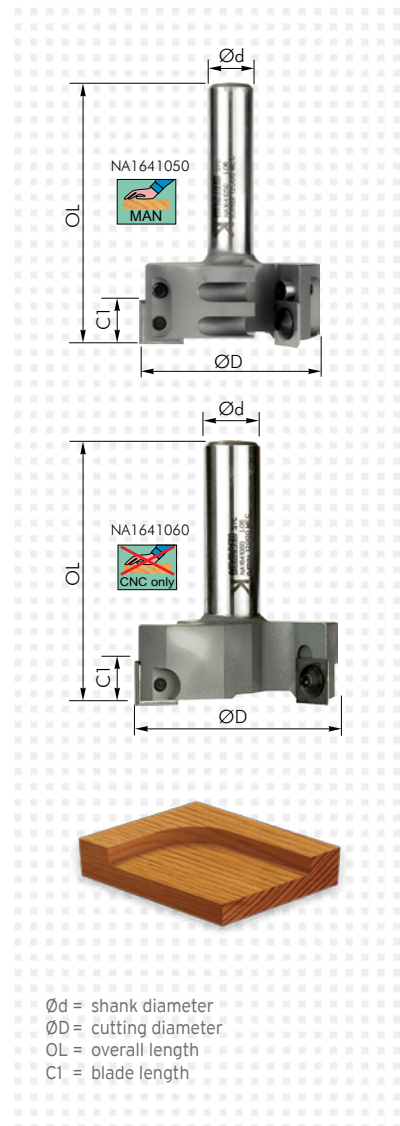



CNC ROUTER CUTTERS

Multi Profile Moulding Set - Reversible Knives



A boxed set of reversible swop-tip[®] knives and holder to produce four sizes of Round Over, four sizes of Cove and a 45 degree Chamfer.

Part Number	ØD	OL	Ød	Shank C1	Price (Ex VAT)
NA1871628	28mm	80mm	12mm	50mm	£222.20

Spare Parts	Description	Price (Ex VAT)
NA1871602	Body only	£98.10
NA1871604	Box, set of knives, no body	£124.10
NA1870120	Knife Cove Profile ØD1=24, Ra=2	£9.25
NA1870130	Knife Cove Profile ØD1=22, Ra=3	£9.25
NA1870140	Knife Cove Profile ØD1=20, Ra=4	£9.25
NA1870150	Knife Cove Profile ØD1=18, Ra=5	£9.25
NA1870160	Knife Cove Profile ØD1=16, Ra=6	£9.25
NA1870230	Knife Round Over Profile ØD1=22, Rb=3	£9.25
NA1870240	Knife Round Over Profile ØD1=20, Rb=4	£9.25
NA1870250	Knife Round Over Profile ØD1=18, Rb=5	£9.25
NA1870260	Knife Round Over Profile ØD1=16, Rb=6	£9.25
NA1870060	Knife 45 degree Chamfer ØD1=16, Rd=6	£9.25
TQ406	Torx Screw	£1.36
NA0050015	Torx Key T15	£2.04

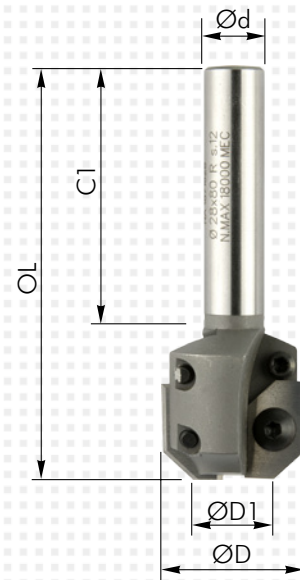

Ød = shank diameter
 ØD = cutting diameter
 ØD1 = cutting diameter 1
 OL = overall length
 C1 = shank length
 Ra = cove radius
 Rb = round over radius
 Rd = chamfer width

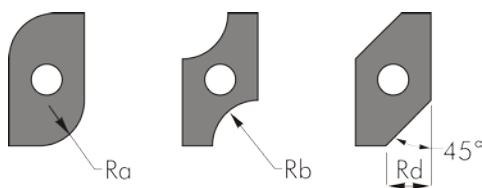

wealdentool.com

Sales: 01580 890500 Fax: 01580 890222 Email: sales@wealdentool.com



CNC ROUTER CUTTERS

Multi Profile Set - Replaceable Tips



A boxed set of ten single flute swop-tip[®] knives and holder to produce a wide variety of profiles.

Part Number	ØD	OL	Ød	Shank C1	Price (Ex VAT)
NA1921336	16mm	70mm	1/2 inch	50mm	£142.70

Spare Parts	Description	Price (Ex VAT)
NA1921316	Body only	£67.20
NA1921326	Box, set of knives, no body	£75.50
NA192131A	Knife Profile A	£9.50
NA192131B	Knife Profile B	£9.50
NA192131C	Knife Profile C	£9.50
NA192131D	Knife Profile D	£9.50
NA192131E	Knife Profile E	£9.50
NA192131F	Knife Profile F	£9.50
NA192131G	Knife Profile G	£9.50
NA192131H	Knife Profile H	£9.50
NA192131I	Knife Profile I	£9.50
NA192131L	Knife Profile L	£9.50
NA0050015	Torx Key	£2.04

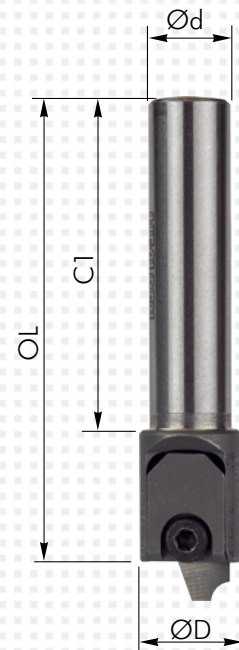

Ød = shank diameter
 ØD = cutting diameter
 OL = overall length

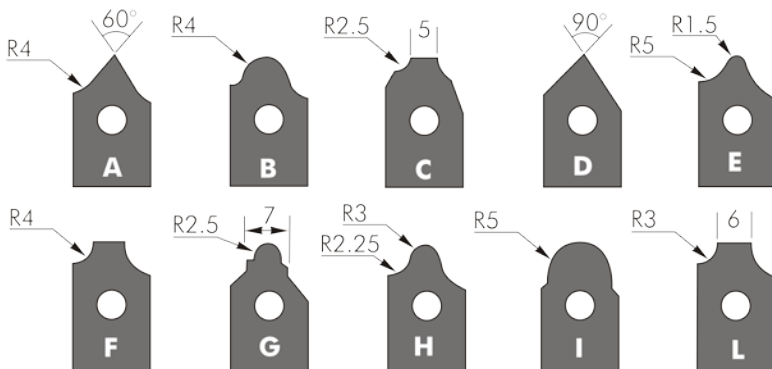

wealdentool.com

Sales: 01580 890500 Fax: 01580 890222 Email: sales@wealdentool.com





Multi Profile System



Multi profile cutter to take the complete range of 40 x 4mm and 50 x 4mm knives. Suitable for profiling in softwoods, hardwoods and man-made boards (TCT knives only) on routers and machining centres with CNC control.
N.B. Maximum speed 12,000 r.p.m.

This cutterhead is supplied complete with rebating knives and will accept any of the F121 or F131 series Euro knives from our spindle moulding range.

Part Number	ØD	C1	OL	Ød	C2	Price (Ex VAT)
NA8710061	66mm	40-50mm	98mm	20mm	55mm	£124.30
NA8710060	66mm	40-50mm	98mm	25mm	55mm	£124.30

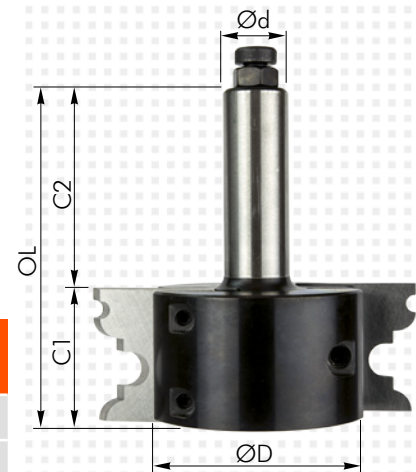

Spare Parts	Description	Size	Price (Ex VAT)
F121191	Rebate Knife	40x20x4mm	£5.92
F003025	Wedge	L=38mm	£8.57
NA0003127	Set Screw	M8 x 12	£0.78
NA0003134	Hex Key	4mm	£4.05



Ød = shank diameter
 ØD = cutting diameter
 OL = overall length
 C1 = blade length
 C2 = shank length



wealdentool.com

Sales: 01580 890500 Fax: 01580 890222 Email: sales@wealdentool.com



Bull Nose Profile



Swop-tip[®] profile cutter with four different sizes of bull nose profile.

Replaceable tip cutters offer the benefit of a constant diameter and easy maintenance without removal from the machine.

Part Number	ØD	R1	OL	Ød	C1	Price (Ex VAT)
NA1892050	50mm	5.0mm	90mm	20mm	50mm	£180.00
NA1892075	60mm	7.5mm	95mm	20mm	50mm	£180.00
NA1892100	60mm	10.0mm	100mm	20mm	50mm	£192.50
NA1892125	70mm	12.5mm	100mm	20mm	50mm	£192.50

Spare Parts	Description	Size	Price (Ex VAT)
NA1890050	Knife	Radius = 5.0mm	£12.45
NA1890075	Knife	Radius = 7.5mm	£13.75
NA1890100	Knife	Radius = 10.0mm	£14.35
NA1890125	Knife	Radius = 12.5mm	£14.95
TQ406	Torx screw	M4 x 6	£1.36
KT15	Torx Key	T15	£2.04

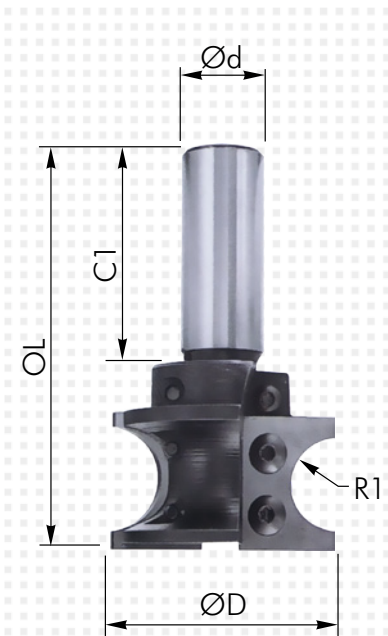

Ød = shank diameter
 R1 = radius
 ØD = cutting diameter
 OL = overall length
 C1 = shank length





CNC ROUTER CUTTERS

Ovolo/Beading Cutter



A versatile swop-tip[®] cutter available in three different body sizes with a selection of radii from 8mm to 20mm.

Replaceable tip cutters offer the benefit of a constant diameter and easy maintenance without removal from the machine.

Part Number	ØD	C1	R	OL	Ød	C2	Price (Ex VAT)
NA1882008	32mm	18.5mm	8mm	80mm	20mm	50mm	£147.40
NA1882010	36mm	23.5mm	10mm	85mm	20mm	50mm	£147.40
NA1882012	40mm	23.5mm	12mm	85mm	20mm	50mm	£167.90
NA1882015	46mm	28.5mm	15mm	90mm	20mm	50mm	£167.90
NA1882020	56mm	34.0mm	20mm	95mm	20mm	50mm	£173.30

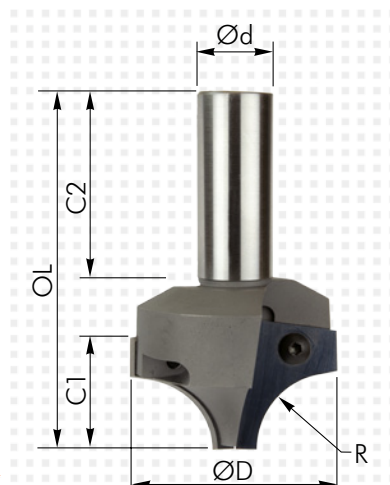

Ød = shank diameter
 ØD = cutting diameter
 OL = overall length
 R = radius
 C1 = maximum cutting depth
 C2 = shank length

Spare Parts	Description	Size	Price (Ex VAT)
NA0051808	Knife	R = 8mm	£12.10
NA0051810	Knife	R = 10mm	£12.10
NA0051812	Knife	R = 12mm	£12.10
NA0051815	Knife	R = 15mm	£12.10
NA0051820	Knife	R = 20mm	£12.10
TQ406	Screw	M4 x 6	£1.36
NA0050015	Torx key	T15	£2.04





V-Groove Chamfer Replaceable Tip Cutter



Single flute TC swop-tip[®] cutter for 45° chamfers and V-cuts.

Replaceable tip cutters offer the benefit of a constant diameter and easy maintenance without removal from the machine.

Part Number	ØD	C1	OL	Ød	C2	Price (Ex VAT)
NA1912027	58mm	27mm	105mm	20mm	50mm	£149.25

Spare Parts	Description	Size	Price (Ex VAT)
NA0050390	Knife	39x12x1.5mm	£4.29
TQ406	Screw	M4 x 6	£1.36
KT15	Torx key	T15	£2.04

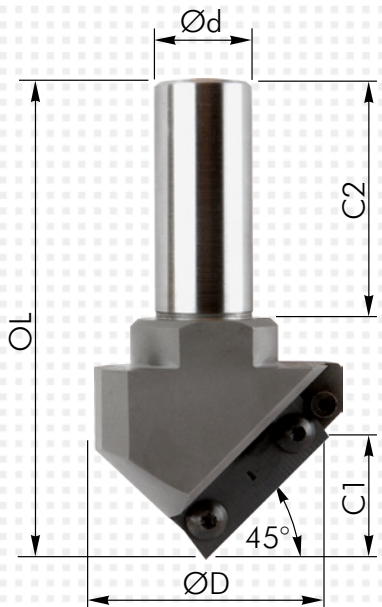

Ød = shank diameter
 ØD = cutting diameter
 OL = overall length
 C1 = blade length
 C2 = max cutting depth



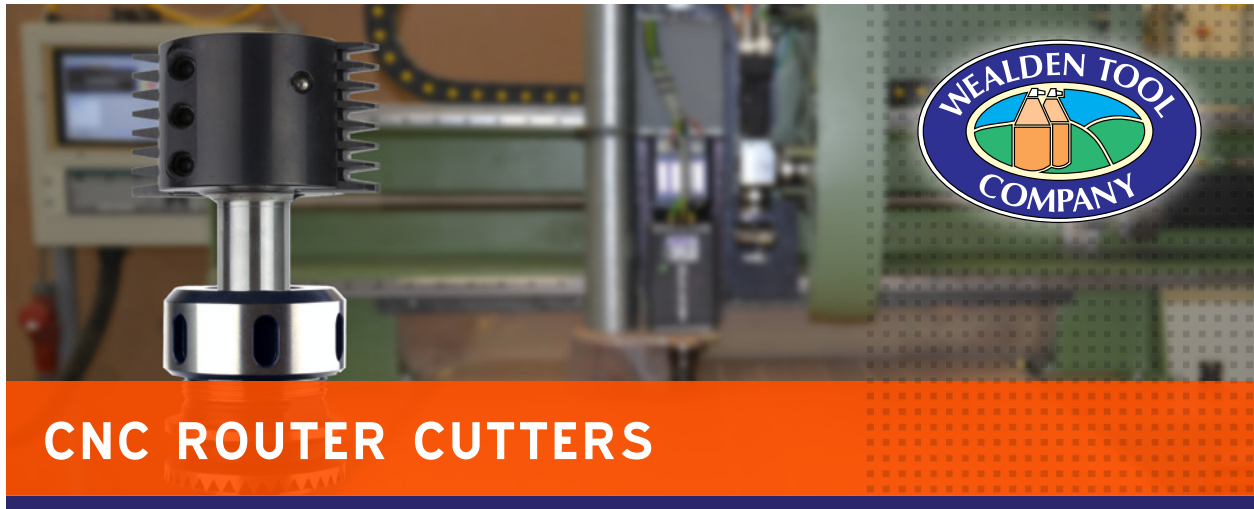

Finger Joint Cutter



Swop-tip® finger jointing router cutter complete with two cutting flutes. Suitable for producing finger joints in softwoods, hardwoods and man-made boards.

N.B. Maximum speed 12,000 r.p.m.

Replaceable tip cutters offer the benefit of a constant diameter and easy maintenance without removal from the machine.

Part Number	ØD	C1	OL	Ød	Price (Ex VAT)
NA8560111	70mm	40mm	100mm	20mm	£282.00

Spare Parts	Description	Size	Price (Ex VAT)
NA8560110	TC Knife	40x28x1.5mm	£36.24
F003027	Backing plate	40x22.5x4	£15.42
F003127	Hex Screw	M8 x 12	£0.78
F003026	Wedge	40x13.5x8	£7.74
F003134	Hex Key	S4	£4.05

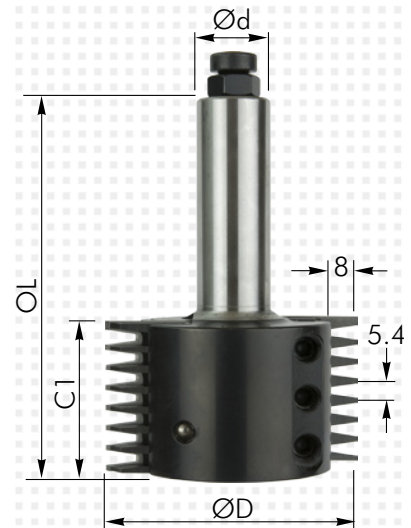

Ød = shank diameter
 ØD = cutting diameter
 OL = overall length
 C1 = blade length





STC ROUTER CUTTERS

Engraving V Bits



Solid carbide single flute engraving bits, available in three different included angles.

Part Number	∠°	OL	∅d	Price (Ex VAT)
T3S5090	90°	51.5mm	3mm	£7.79
T3S5060	60°	52.6mm	3mm	£7.79
T3S5045	45°	53.6mm	3mm	£7.79
T3S5030	30°	55.6mm	3mm	£7.79
NA7600809	90°	60mm	8mm	£23.60
NA7600806	60°	60mm	8mm	£23.60
NA7600804	45°	60mm	8mm	£23.60

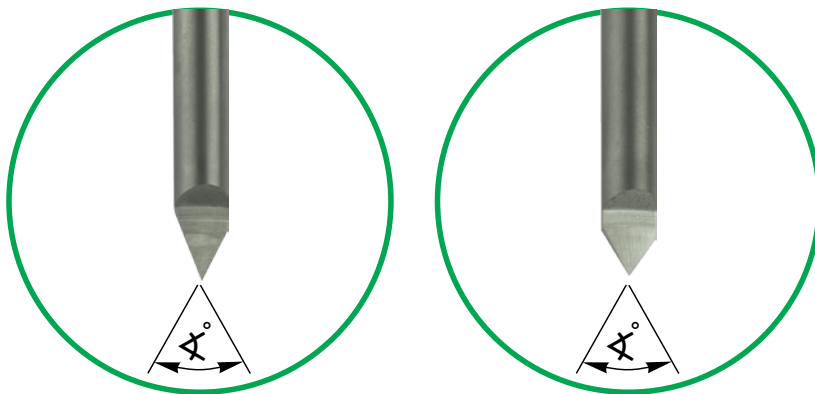
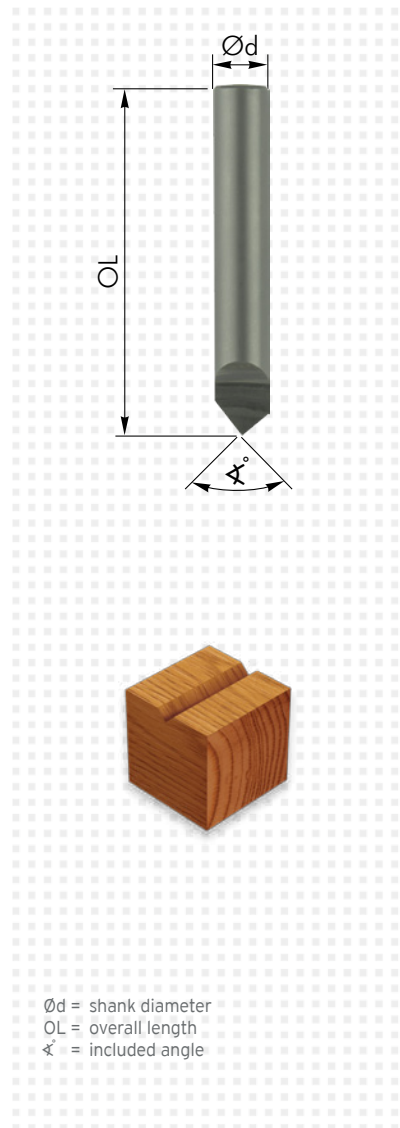

wealdentool.com

Sales: 01580 890500 Fax: 01580 890222 Email: sales@wealdentool.com





CNC ROUTER CUTTERS

Adjustable Grooving Cutter



Hard-wearing steel body complete with disposable tungsten carbide knives and scorers for improved finish. Suitable for producing various thickness grooves and slots in softwood, hardwood and man-made boards (with or without coating).
N.B. Maximum speed 8,000 r.p.m.

Cutting width can be adjusted in 0.25mm steps by using spacer rings supplied. Replaceable inserts ensure a constant cutting diameter and finish quality.

Part Number	ØD	C1	OL	Ød	C2	Price (Ex VAT)
NA6171420	140mm	4 - 15.5mm	95mm	20mm	50mm	£300.00

Spare Parts	Description	Size	Price (Ex VAT)
NA6171408	Shim set	2 each 0.25mm, 0.5mm, 1mm, 2mm	£13.50
F000455	TC knife	18 x 18 x 1.95	£4.79
F000470	TC scribe	14 x 14 x 1.2	£2.43
F000450	TC knife	7.5 x 12 x 1.5	£2.65

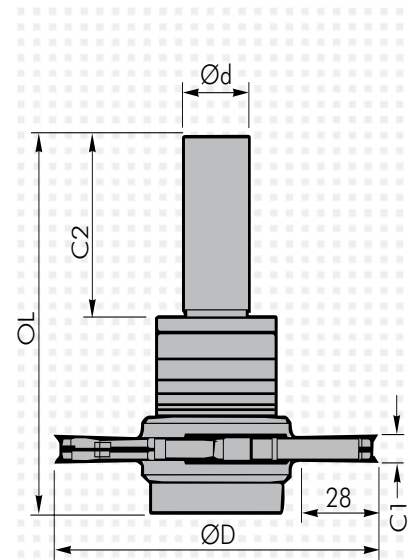

Ød = shank diameter
 ØD = cutting diameter
 OL = overall length
 C1 = groove width
 C2 = shank length



wealdentool.com

Sales: 01580 890500 Fax: 01580 890222 Email: sales@wealdentool.com



Ball Nose Profile



Swop-tip© disposable insert profile cutter with five different sizes of ball nose profile.

Swop-tip© cutters offer the benefit of a constant diameter and easy maintenance without removal from the machine.

Part Number	ØD	R1	OL	Ød	C1	Price (Ex VAT)
NA1902005	10mm	5.0mm	100mm	20mm	38mm	£84.30
NA1902006	12mm	6.0mm	100mm	20mm	40mm	£92.20
NA1902008	16mm	8.0mm	110mm	20mm	50mm	£98.60
NA1902010	20mm	10.0mm	110mm	20mm	50mm	£106.00
NA1902015	30mm	15.0mm	115mm	20mm	60mm	£135.60

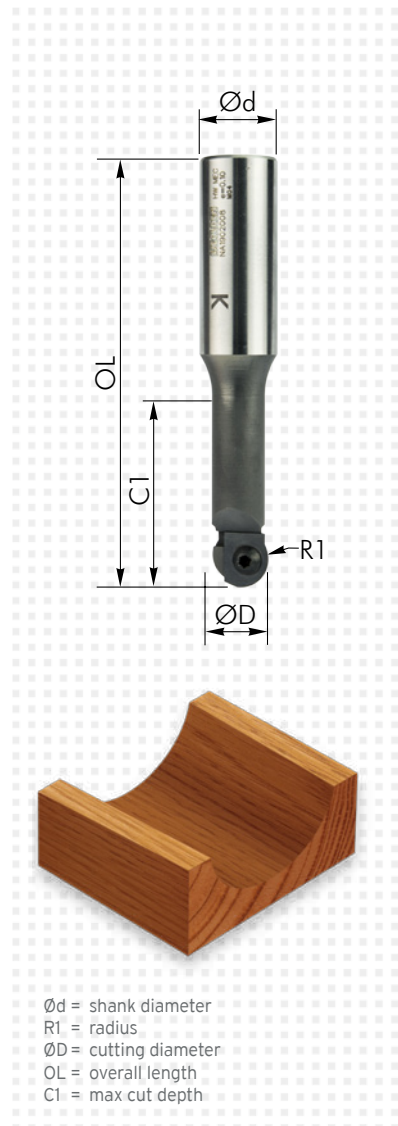

Spare Parts	Description	Size	Price (Ex VAT)
NA1902105	TC Knife	Radius = 5.0mm	£13.00
NA1902106	TC Knife	Radius = 6.0mm	£13.00
NA1902108	TC Knife	Radius = 8.0mm	£13.00
NA1902110	TC Knife	Radius = 10.0mm	£13.00
NA1902115	TC Knife	Radius = 15.0mm	£14.50
TQ354	Torx screw	M3.5 x 4.4 	£1.35
TQ402	Torx screw	M4 x 4 	£1.35
TQ403	Hex screw	M4 x 8 low cap	£0.25
SM4014C	Hex screw	M4 x 14 cap	£0.15
NA0050015	Torx key	T15	£2.04
K25	Hex key	2.5mm	£0.25
K30	Hex key	3.0mm	£0.25

Ød = shank diameter
 R1 = radius
 ØD = cutting diameter
 OL = overall length
 C1 = max cut depth





Arris Rounding



Swop-tip[®] disposable insert arris-rounding cutter in five radius sizes. All radius size knives are interchangeable on the one body.

Swop-tip[®] cutters offer the benefit of a constant diameter and easy maintenance without removal from the machine.

Part Number	ØD	R1	OL	Ød	C1	Price (Ex VAT)
NA1632002	45mm	2.0mm	120mm	20mm	16mm	£84.30
NA1632003	45mm	3.0mm	120mm	20mm	16mm	£92.20
NA1632004	45mm	4.0mm	120mm	20mm	16mm	£98.60
NA1632005	45mm	5.0mm	120mm	20mm	16mm	£106.00
NA1632006	45mm	6.0mm	120mm	20mm	16mm	£135.60

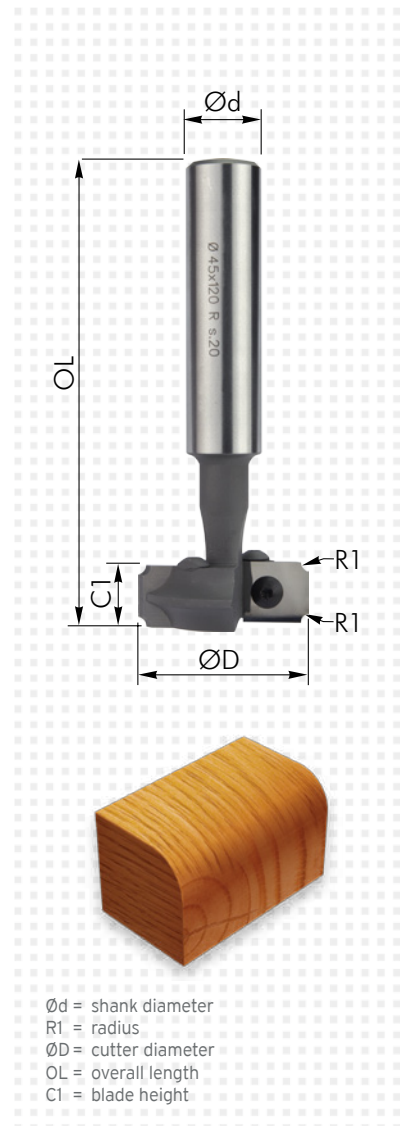

Spare Parts	Description	Size	Price (Ex VAT)
NA1632102	TC Knife single	Radius = 2.0mm	£13.60
NA1632103	TC Knife single	Radius = 3.0mm	£13.60
NA1632104	TC Knife single	Radius = 4.0mm	£13.60
NA1632105	TC Knife single	Radius = 5.0mm	£13.60
NA1632106	TC Knife single	Radius = 6.0mm	£13.60
TQ406	Torx screw	M4 x 6 	£1.36
NA0050015	Torx key	T15	£2.04

Ød = shank diameter
 R1 = radius
 ØD = cutter diameter
 OL = overall length
 C1 = blade height





PCD ROUTER CUTTERS

Bookcase strip compression cutter PCD

Cutters featuring fine grain PCD micro polished tips offer extended life when machining abrasive materials.

These cutters have PCD tips arranged with up-shear on the groove cutter for better waste clearance and down-shear on the rebate cutter for a clean finish on the top edge of the board.

Part Number	ØD	ØD1	C1	Ød	OL	C2	Price (Ex VAT)
NPA4430012	19.5mm	10mm	16mm	12mm	66mm	6mm	£186.00

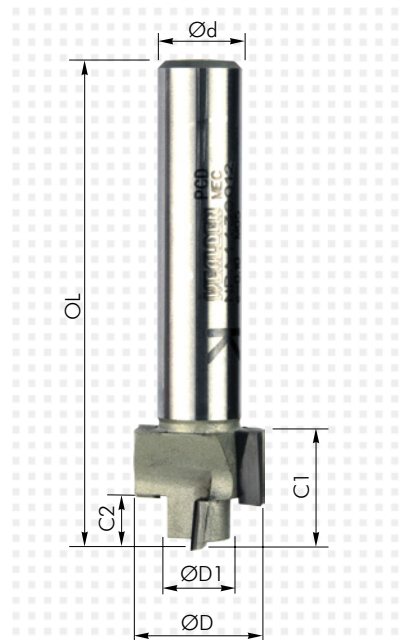

- Ød = shank diameter
- ØD = rebate diameter
- ØD1 = clearance diameter
- OL = overall length
- C1 = clearance depth
- C2 = maximum depth





PCD ROUTER CUTTERS

Down-shear 2 flute cutter PCD

Cutters featuring fine grain PCD micro polished tips offer extended life when machining abrasive materials.

Two fluted cutters with PCD tips in a down-shear configuration for shallow recessing on abrasive material. The down-shear gives a clean cut on the top edge of the board.

Part Number	ØD	C1	Ød	OL	C2	Price (Ex VAT)
NPD11208010	8.0mm	10mm	12mm	70mm	50mm	£65.80
NPD11210010	10.0mm	10mm	12mm	70mm	50mm	£65.80
NPD11212010	12.0mm	10mm	12mm	70mm	50mm	£65.80

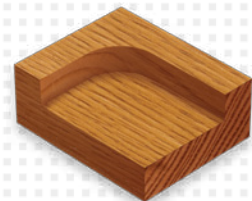
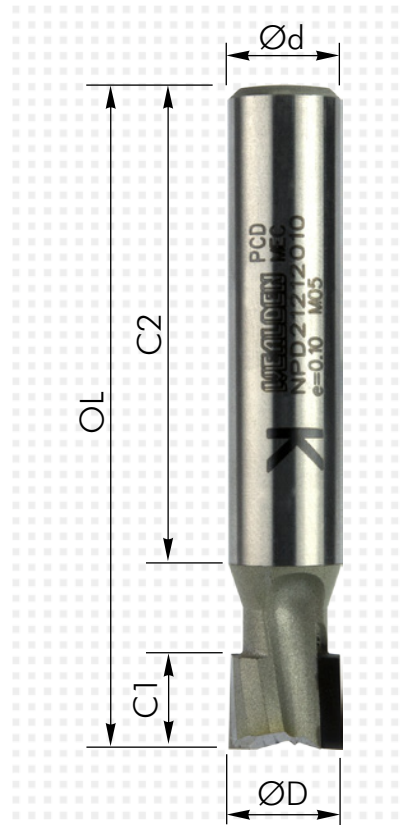

- Ød = shank diameter
- ØD = cut diameter
- OL = overall length
- C1 = cut length
- C2 = shank length



wealdentool.com

Sales: 01580 890500 Fax: 01580 890222 Email: sales@wealdentool.com



PCD ROUTER CUTTERS

Economy Spiral Compression PCD

Economical disposable cutters featuring micro polished PCD flutes with a TC plunge tip. It is not possible to re-sharpen these cutters.

Standard RH rotation segmented spiral flute cutters with PCD tips in up-down shear configuration for nesting on abrasive materials. This configuration gives a good finish on both edges of the board.

Part Number	ØD mm	C1 mm	Ød mm	OL mm	C2 mm	Price (Ex VAT)
NPC11212025	12.0	25	12	76	10	£59.50
NPC11212035	12.0	35	12	83	10	£66.50
NPC12016025	16.0	25	20	87	10	£62.60
NPC12016035	16.0	35	20	96	10	£68.50
NPC12016044	16.0	44	20	105	10	£87.60
NPC12016052	16.0	52	20	113	10	£105.25
NPC12018025	18.0	25	20	87	10	£62.60
NPC12018035	18.0	35	20	96	10	£68.50
NPC12018044	18.0	44	20	105	10	£87.60
NPC12018052	18.0	52	20	113	10	£105.25
NPC12020025	20.0	25	20	87	10	£62.60
NPC12020035	20.0	35	20	96	10	£68.50
NPC12020044	20.0	44	20	105	10	£87.70
NPC12020052	20.0	52	20	113	10	£105.25

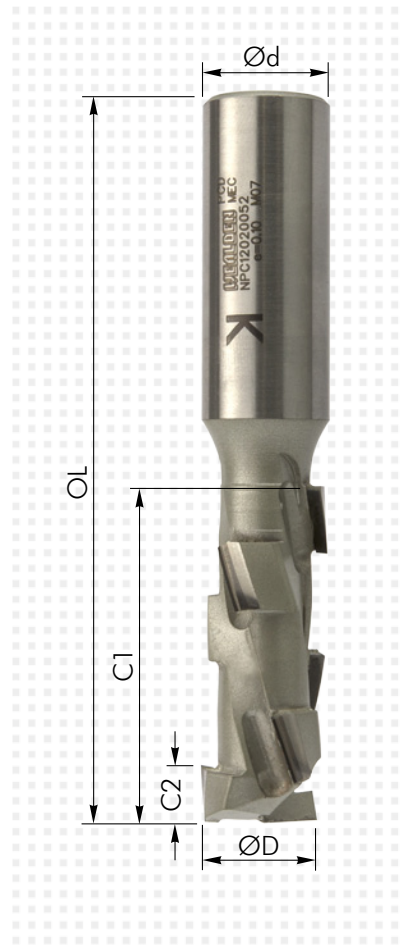

- Ød = shank diameter
- ØD = cut diameter
- OL = overall length
- C1 = cutting length
- C2 = up-shear length

wealdentool.com

Sales: 01580 890500 Fax: 01580 890222 Email: sales@wealdentool.com





PCD ROUTER CUTTERS

Spiral Compression PCD

High performance re-servicable* cutters with micro polished PCD tips on Densimet/Triamet® shanks.

These high feed rate production cutters feature a high rigidity body and segmented spiral flutes with PCD tips in up-down shear configuration. Designed for nesting and production sizing on MFC (furniture board), this configuration gives a good finish on both edges of the board.

PCD outlives tungsten carbide by well over 40-60 times. Extended life cuts down set-up time and PCD offers reliable high quality finish and accuracy on abrasive materials, which take the edge off tungsten carbide cutters.

Part Number	ØD mm	C1 mm	Ød mm	OL mm	C2 mm	Price (Ex VAT)
NSC11208019	8.0	18	12	70	5	£130.00
NSC11208021	8.0	21	12	70	5	£130.00
NSC11208025	8.0	25	12	70	5	£165.00
NSC11210025	10.0	25	12	70	5	£165.00
NSC11210033	10.0	33	12	90	5	£180.00
NSC11212027	12.0	27	12	80	5	£165.00
NSC11616030	16.0	30	16	90	5	£202.50

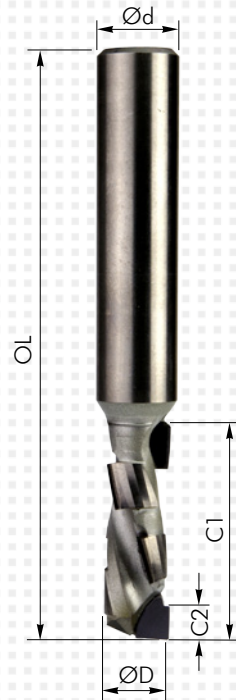

CARE & USE OF PCD

Polycrystalline Diamond has a high abrasive resistance, yet it can easily be damaged. If cutters are dropped, knocked or otherwise abused irreparable damage may be caused.

* SERVICING

Re-servicable cutters can be sharpened two to four times depending on the amount of wear on the tips, but please be aware that the cutting diameter will reduce at each servicing.

- Ød = shank diameter
- ØD = cut diameter
- OL = overall length
- C1 = cutting length
- C2 = up-shear length



wealdentool.com

Sales: 01580 890500 Fax: 01580 890222 Email: sales@wealdentool.com



TCT DRILLING TOOLING

Dowel drills

Multi-boring dowel drills with TC tips.
The drills have 10mm cylindrical shank with flat and length adjustment screw.

RH Part Number	LH Part Number	ØD	C1	Price (Ex VAT)
LIP & SPUR – 57mm length				
DD57030R	DD57030L	3.0mm	25mm	£10.50
DD57040R	DD57040L	4.0mm	25mm	£9.08
DD57050R	DD57050L	5.0mm	25mm	£9.25
DD57060R	DD57060L	6.0mm	25mm	£9.71
DD57070R	DD57070L	7.0mm	25mm	£10.25
DD57075R	DD57075L	7.5mm	25mm	£11.04
DD57080R	DD57080L	8.0mm	25mm	£11.17
DD57095R	DD57095L	3/8"	25mm	£12.17
DD57100R	DD57100L	10.0mm	25mm	£12.17
DD57120R	DD57120L	12.0mm	25mm	£15.11
DD57150R	DD57150L	15.0mm	25mm	£22.42
DD57160R	DD57160L	16.0mm	25mm	£22.83
DD57170R	DD57170L	17.0mm	25mm	£23.00

LIP & SPUR – 70mm length				
DD70030R	-	3.0mm	32mm	£12.25
DD70040R	DD70040L	4.0mm	35mm	£9.83
DD70050R	DD70050L	5.0mm	35mm	£10.42
DD70060R	DD70060L	6.0mm	35mm	£10.67
DD70063R	DD70063L	6.35mm	35mm	£10.92
DD70075R	DD70075L	7.5mm	35mm	£10.96
DD70080R	DD70080L	8.0mm	35mm	£11.08
DD70095R	DD70090L	9.53mm	35mm	£13.86
DD70100R	DD70100L	10.0mm	35mm	£13.86
DD70120R	DD70120L	12.0mm	35mm	£15.96
DD70127R	DD70127L	12.7mm	35mm	£20.33

V POINT 60° – 57mm length				
DV57040R	DV57040L	4.0mm	25mm	£11.58
DV57050R	DV57050L	5.0mm	25mm	£11.71
DV57060R	DV57060L	6.0mm	25mm	£12.61
DV57080R	DV57080L	8.0mm	25mm	£15.00
DV57100R	DV57100L	10.0mm	25mm	£15.83
DV57120R	DV57120L	12.0mm	25mm	£18.61

V POINT 60° – 70mm length				
DV70040R	DV70040L	4.0mm	35mm	£11.58
DV70050R	DV70050L	5.0mm	35mm	£11.71
DV70060R	DV70060L	6.0mm	35mm	£12.61
DV70075R	DV70075L	7.5mm	35mm	£15.00
DV70100R	DV70100L	10.0mm	35mm	£15.83
DV70120R	DV70120L	12.0mm	35mm	£18.61

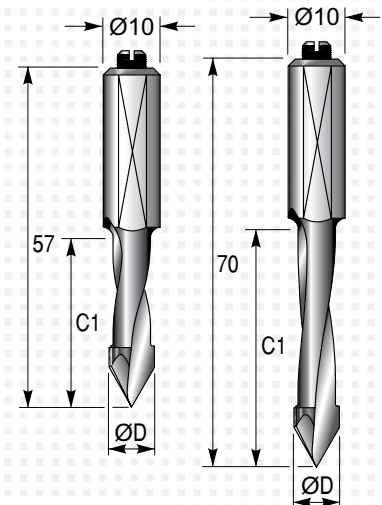
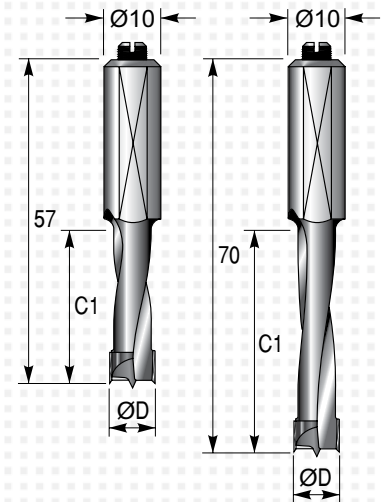

ØD = drilling diameter
C1 = flute length

wealdentool.com

Sales: 01580 890500 Fax: 01580 890222 Email: sales@wealdentool.com





TCT DRILLING TOOLING

Cylinder boring drills

Tungsten carbide tipped boring bits with 2 pointed spurs, centring point and two blades. The drills have 10mm cylindrical shank with flat and length adjustment screw. For use on multi-borers, automatics and CNC machines. A reducer sleeve (TA7) is also available to enable the shank to fit in a 1/2" collet. Suitable for cutting hard wood, soft wood and man made boards.

RH Part Number	LH Part Number	ØD	C1	Price (Ex VAT)
----------------	----------------	----	----	----------------

CYLINDER bits- 57.5mm length (z = 2+2)

DS57015R	DS57015L	15.0mm	57.5mm	£19.25
DS57016R	DS57016L	16.0mm	57.5mm	£19.60
DS57017R	DS57017L	17.0mm	57.5mm	£19.95
DS57018R	DS57018L	18.0mm	57.5mm	£19.95
DS57020R	DS57020L	20.0mm	57.5mm	£20.50
DS57022R	DS57022L	22.0mm	57.5mm	£20.90
DS57024R	DS57024L	24.0mm	57.5mm	£21.30
DS57025R	DS57025L	25.0mm	57.5mm	£21.30
DS57026R	DS57026L	26.0mm	57.5mm	£21.75
DS57028R	DS57028L	28.0mm	57.5mm	£22.55
DS57030R	DS57030L	30.0mm	57.5mm	£22.55
DS57032R	DS57032L	32.0mm	57.5mm	£22.96
DS57035R	DS57035L	35.0mm	57.5mm	£22.96
DS57040R	DS57040L	35.0mm	57.5mm	£29.30

CYLINDER bits - 70mm length (z = 2+2)

DS70015R	DS70015L	15.0mm	70.0mm	£20.50
DS70016R	DS70016L	16.0mm	70.0mm	£20.80
DS70018R	DS70018L	18.0mm	70.0mm	£21.30
DS70020R	DS70020L	20.0mm	70.0mm	£21.50
DS70025R	DS70025L	25.0mm	70.0mm	£22.55
DS70026R	DS70026L	26.0mm	70.0mm	£22.95
DS70030R	DS70030L	30.0mm	70.0mm	£23.70
DS70035R	DS70035L	35.0mm	70.0mm	£23.75
DS70040R	DS70040L	40.0mm	70.0mm	£30.55

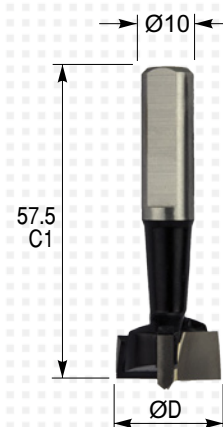

ØD = drilling diameter
C1 = overall length





COLLETS ER SERIES

ER Collets series 20-25-32-40

High precision collets for EN series tool holders. Manufactured to DIN6499/B.

ER20

Ød shank	Part number	Price ex VAT	Ød shank	Part number	Price ex VAT
3mm	NER2000030	£12.30	8mm	NER2000080	£12.30
1/8"	NER2000032	£12.30	3/8"	NER2000095	£12.30
4mm	NER2000040	£12.30	10mm	NER2000100	£12.30
5mm	NER2000050	£12.30	12mm	NER2000120	£12.30
6mm	NER2000060	£12.30	1/2"	NER2000127	£12.30
1/4"	NER2000063	£12.30	13mm	NER2000130	£12.30

ER25

Ød shank	Part number	Price ex VAT	Ød shank	Part number	Price ex VAT
3mm	NER2500030	£12.30	3/8"	NER2500095	£12.30
1/8"	NER2500032	£12.30	10mm	NER2500100	£12.30
4mm	NER2500040	£12.30	12mm	NER2500120	£12.30
5mm	NER2500050	£12.30	1/2"	NER2500127	£12.30
6mm	NER2500060	£12.30	13mm	NER2500130	£12.30
1/4"	NER2500063	£12.30	14mm	NER2500140	£12.30
8mm	NER2500080	£12.30	16mm	NER2500160	£12.30

ER32

Ød shank	Part number	Price ex VAT	Ød shank	Part number	Price ex VAT
3mm	NER3200030	£12.30	12mm	NER3200120	£12.30
4mm	NER3200040	£12.30	1/2"	NER3200127	£12.30
5mm	NER3200050	£12.30	13mm	NER3200130	£12.30
6mm	NER3200060	£12.30	14mm	NER3200140	£12.30
1/4"	NER3200063	£12.30	16mm	NER3200160	£12.30
8mm	NER3200080	£12.30	18mm	NER3200180	£12.30
3/8"	NER3200095	£12.30	20mm	NER3200200	£12.30
10mm	NER3200100	£12.30			

ER40

Ød shank	Part number	Price ex VAT	Ød shank	Part number	Price ex VAT
3mm	NER4000030	£16.15	1/2"	NER4000127	£16.15
4mm	NER4000040	£16.15	13mm	NER4000130	£16.15
5mm	NER4000050	£16.15	14mm	NER4000140	£16.15
6mm	NER4000060	£16.15	16mm	NER4000160	£16.15
1/4"	NER4000063	£16.15	18mm	NER4000180	£16.15
8mm	NER4000080	£16.15	20mm	NER4000200	£16.15
3/8"	NER4000095	£16.15	22mm	NER4000220	£16.15
10mm	NER4000100	£16.15	24mm	NER4000240	£16.15
12mm	NER4000120	£16.15	25mm	NER4000250	£16.15
			30mm	NER4000300	£24.00

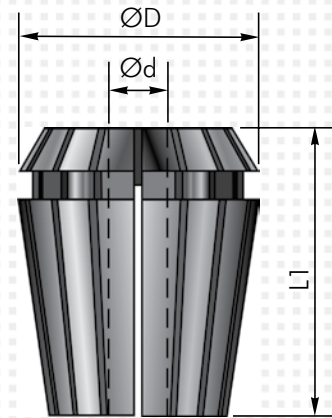

	ER20	ER25	ER32	ER40
ØD	21mm	26mm	33mm	41mm
L1	31.5mm	35mm	40mm	46mm

Ød = cutter shank diameter

Collet shank sizes

The ER collet series was designed to be compressible. Often marked with two sizes, the larger dimension is the machined bore size.

Cutter life and cutting performance are reduced when the collet size does not **exactly** match the cutter shank. Therefore if a collet is marked, for example 6-5, it should only be used for cutters of 6mm shank and not any smaller.



wealdentool.com

Sales: 01580 890500 Fax: 01580 890222 Email: sales@wealdentool.com



OZ COLLETS & ASSEMBLY DEVICES

OZ25 Series collets

High precision collets for Perske type SYOZ series tool holders.
Manufactured to DIN6388/A.

Ød shank	Part number	Price ex VAT
1/4"	NRT2500063	£17.30
8mm	NRT2500080	£17.30
3/8"	NRT2500095	£17.30
10mm	NRT2500100	£17.30
12mm	NRT2500120	£17.30
1/2"	NRT2500127	£17.30
14mm	NRT2500140	£17.30
16mm	NRT2500160	£17.30
20mm	NRT2500200	£17.30

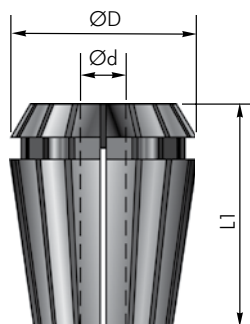

OZ25
 ØD 35mm
 L1 52mm
 Ød = cutter shank diameter

Tool holder assembly device

Heavy duty holder used to assemble and dis-assemble tooling.
The bi-directional clutch safely and firmly grips tool holders
without damage.
May be mounted vertically or horizontally onto a workbench.

Part Number	Toolholder series	Toolholder diameter	Price (Ex VAT)
NAD1030	ISO30	50mm	£162.50
NAD1063	HSK63	63mm	£162.50



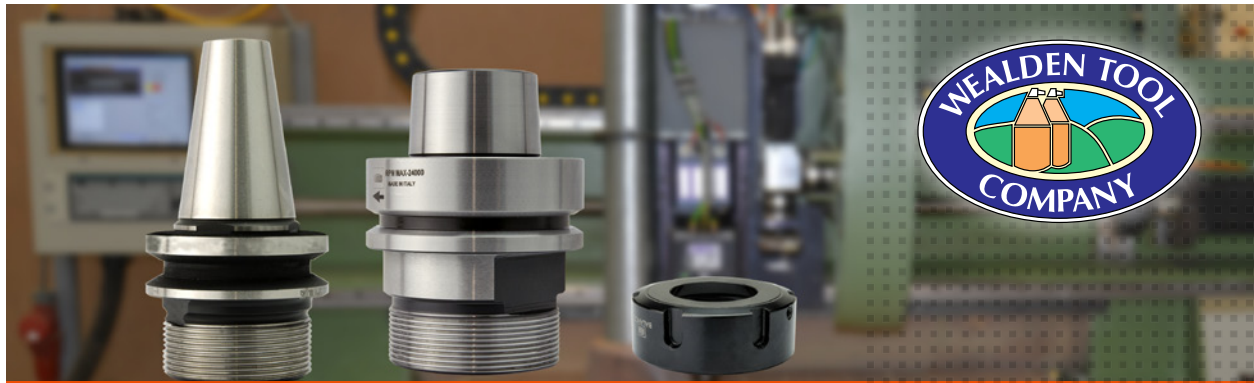

TOOL HOLDERS & NUTS

HSK63-F tool holders

Precision CNC tool holders supplied **without nuts or collets**.
Nuts and collets should be ordered separately if required.

Part Number	ØD	C1	C2	Collet series	Price (Ex VAT)
NTK3201R	40mm	60mm	18mm	ER32	£68.65
NTK4002R	50mm	60mm	18mm	ER40	£74.50



ISO30 tool holders

Precision CNC tool holders supplied **without nuts, collets or pull studs**.
Nuts, collets & pull studs should be ordered separately if required.

Part Number	ØD	C1	C2	Collet series	Price (Ex VAT)
NTS3201R	40mm	33mm	8mm	ER32	£61.95
NTS3202R	40mm	51mm	8mm	ER32	£96.60
NTS4007R	50mm	39mm	8mm	ER40	£63.00



Nuts for tool holders

Precision nuts for CNC tool holders. All nuts are balanced and the ER32 and ER40 nuts are available as standard or ball bearing type.

Part Number	Collet series	Nut type	Price (Ex VAT)
NNS20R	ER20	Standard	£24.96
NNS25R	ER25	Standard	£23.00
NNS32R	ER32	Standard	£23.00
NNB32R	ER32	Ball bearing	£33.95
NNS40R	ER40	Standard	£23.95
NNB40R	ER40	Ball bearing	£41.95



wealdentool.com

Sales: 01580 890500 Fax: 01580 890222 Email: sales@wealdentool.com



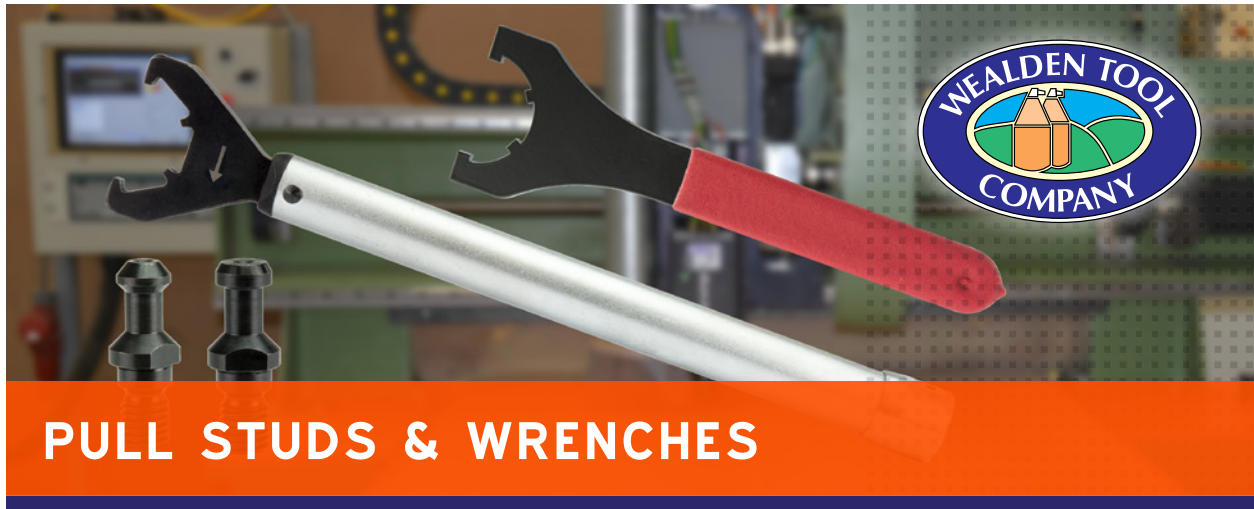

PULL STUDS & WRENCHES

Pull studs for tool holders

The pull stud is the critical link between the tool holder and spindle. Pull studs must always be fully tightened into the tool holder, checked periodically and replaced if worn or damaged. These are not certified as original manufacturers' products.

Part Number	ISO type	Thread	Usage	Price (Ex VAT)
NPS111	ISO30	M12	Busellato, Weeke, Bulleri, Maka	£12.85
NPS113	ISO30	M12	Alberti, Vitap, Masterwood	£13.90
NPS114	ISO30	M12	Esseteam	£12.85
NPS115	ISO30	M12	CMS	£18.75
NPS118	ISO30	M12	Biesse (post 1992), Masterwood	£12.85

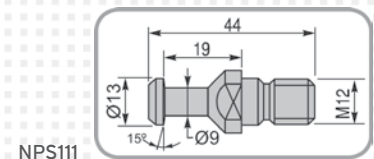

NPS111

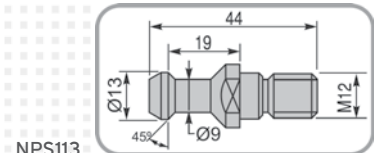

NPS113

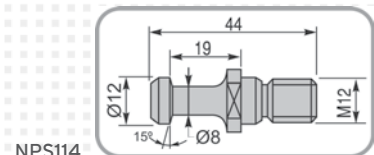

NPS114

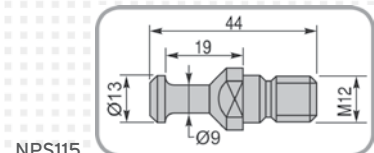

NPS115

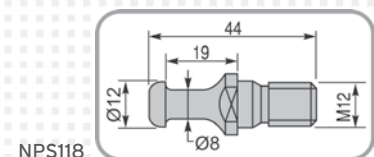

NPS118

Wrenches for ER slotted nuts

Standard steel wrenches with moulded handgrip for ER slotted nuts. In addition to the standard wrenches, torque wrenches are available for ER32 and ER40 nuts. These ensure the correct torque on the nut to maximise the clamping force on the cutter shank without overtightening, which can damage the collet. Each wrench has two settings: one for cutter shanks from 1mm to 7mm and the other for cutter shanks over 7mm.

Part Number	Collet series	Torque up to 7mm shank	Torque from 7mm shank	Price (Ex VAT)
NWC20	ER20	-	-	£18.00
NWC25	ER25	-	-	£18.00
NWC32	ER32	-	-	£19.00
NWC40	ER40	-	-	£19.00
NWT32	ER32	70Nm	130Nm	£129.00
NWT40	ER40	110Nm	200Nm	£154.00



wealdentool.com

Sales: 01580 890500 Fax: 01580 890222 Email: sales@wealdentool.com



www.wealdentool.com



Wealden Tool Company Limited

2, Clinton Business Centre
Lodge Road
Staplehurst
Kent TN12 0QF

Telephone: 01580 890500
Fax: 01580 890222
Email: sales@wealdentool.com